

I-7000 DIO Manual

Warranty

All products manufactured by ICP DAS are warranted against defective materials for a period of one year from the date of delivery to the original purchaser.

Warning

ICP DAS assume no liability for damages consequent to the use of this product. ICP DAS reserves the right to change this manual at any time without notice. The information furnished by ICP DAS is believed to be accurate and reliable. However, no responsibility is assumed by ICP DAS for its use, nor for any infringements of patents or other rights of third parties resulting from its use.

Copyright

Copyright 1999 by ICP DAS. All rights are reserved.

Trademark

The names used for identification only maybe registered trademarks of their respective companies.

Date:1999-08

Table of Contents

1. Introduction	4
1.1 More Information.....	4
1.2 Pin Assignment	5
1.3 Specifications	9
1.4 Block Diagram	13
1.5 Wire Connection	21
1.6 Quick Start	24
1.7 Default Setting	24
1.8 Jumper Setting	24
1.9 Configuration Tables	24
2. Command	26
2.1 %AANNTCCFF	28
2.2 #**	29
2.3 #AABBDD	30
2.4 #AAN	33
2.5 \$AA2	34
2.6 \$AA4	35
2.7 \$AA5	36
2.8 \$AA6	37
2.9 \$AAF	38
2.10 \$AAM	39
2.11 \$AAC	40
2.12 \$AACN	41

2.13 \$AALS	42
2.14 @AA	43
2.15 @AA(Data)	44
2.16 ~AAO(Data)	46
2.17 ~**	47
2.18 ~AA0	48
2.19 ~AA1	49
2.20 ~AA2	50
2.21 ~AA3EVV	51
2.22 ~AA4V	53
2.23 ~AA5V	55
3. Application Note	57
3.1 INIT* pin Operation	57
3.2 Module Status	57
3.3 Dual Watchdog Operation	58
3.4 Reset Status	58
3.5 Digital Output	58
3.6 Latch Digital Input	59
4 DN Module	60
4.1 DN-SSR4	60
4.2 DN-PR4	61
4.3 RM-104, RM-108, RM-116	62
4.4 RM-204, RM-208, RM-216	63
4.5 Application	64

1. Introduction

I-7000 is a family of network data acquisition and control modules. They provide analog-to-digital, digital-to-analog, digital input/output, timer/counter and other functions. These modules can be remote controlled by a set of commands. The DIO modules support TTL signal, photo-isolated digital input, relay contact output , solid-state relay output, PhotoMOS output and open-collector output. Reference *Sec.1.3* for detail information.

1.1 More Information

Refer to “**I-7000 Bus Converter User Manual**” chapter 1 for more information as following:

1.1 I-7000 Overview

1.2 I-7000 Related Documentation

1.3 I-7000 Command Features

1.4 I-7000 System Network Configuration

1.5 I-7000 Dimension

1.2 Pin Assignment

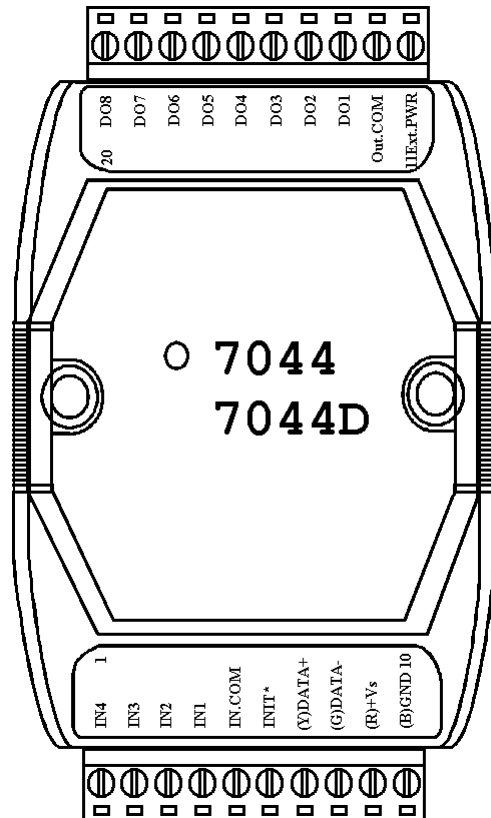
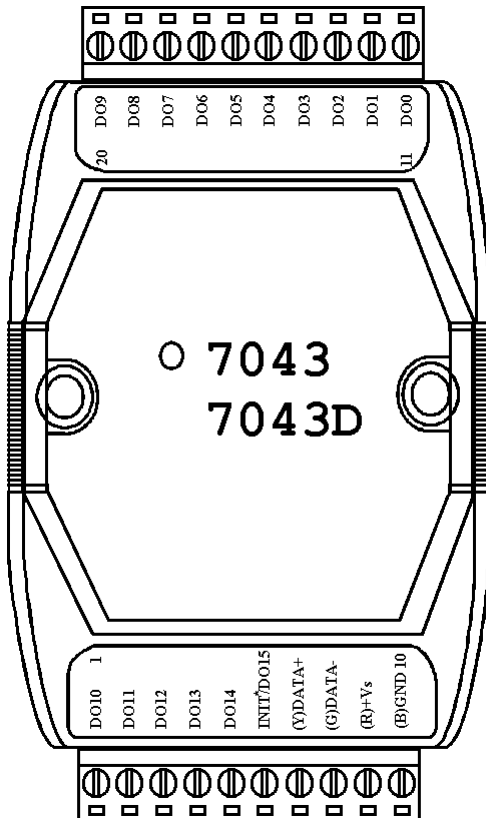
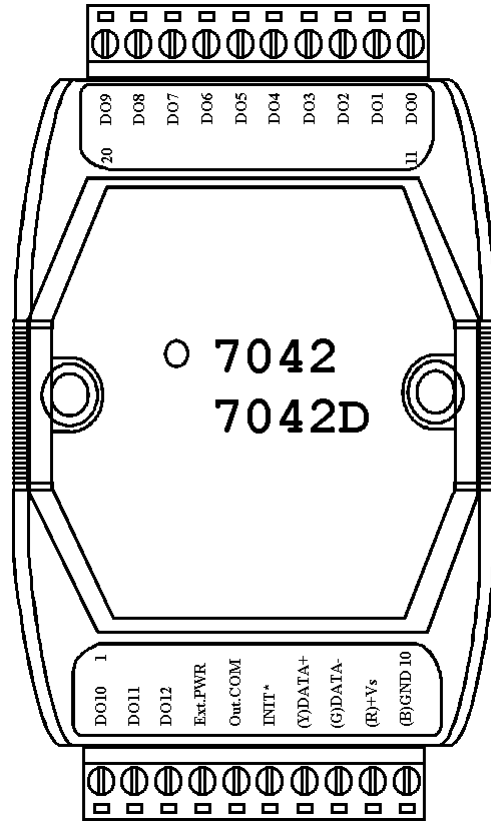
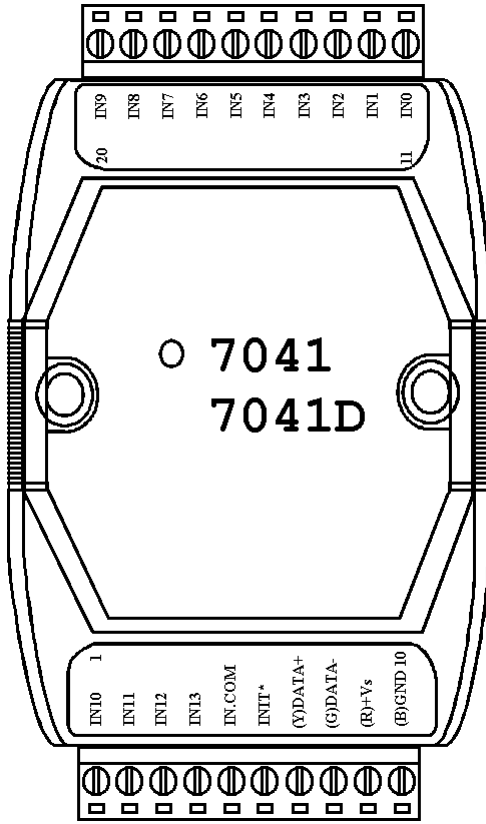

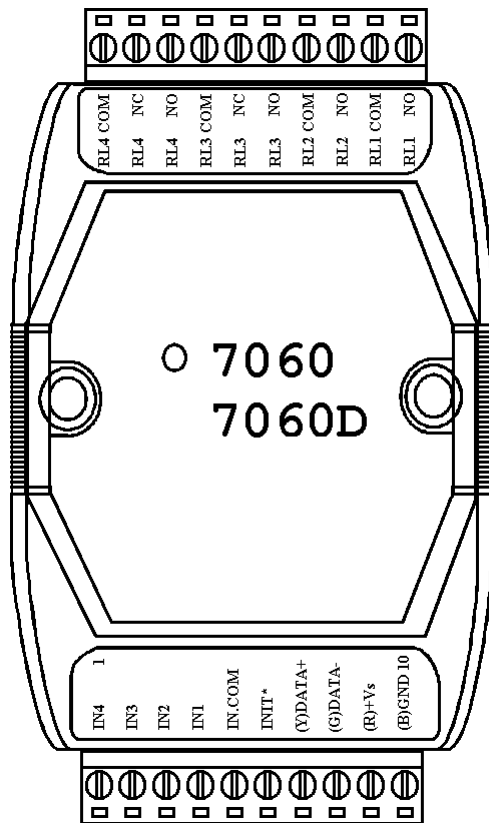
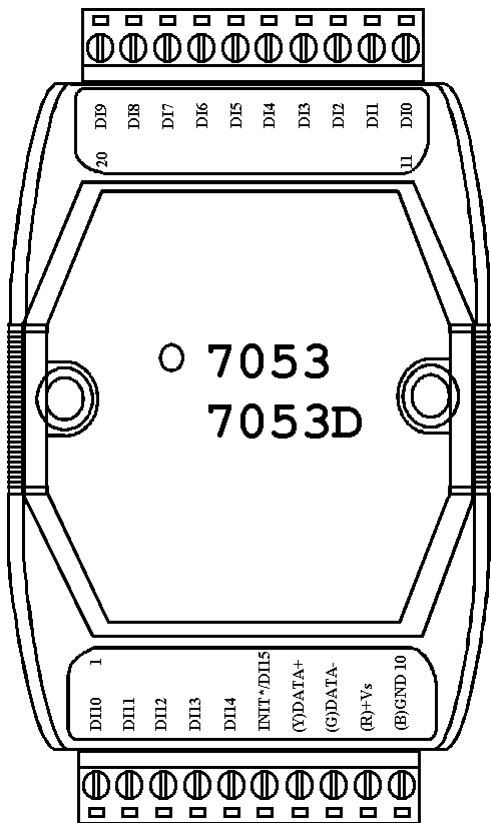
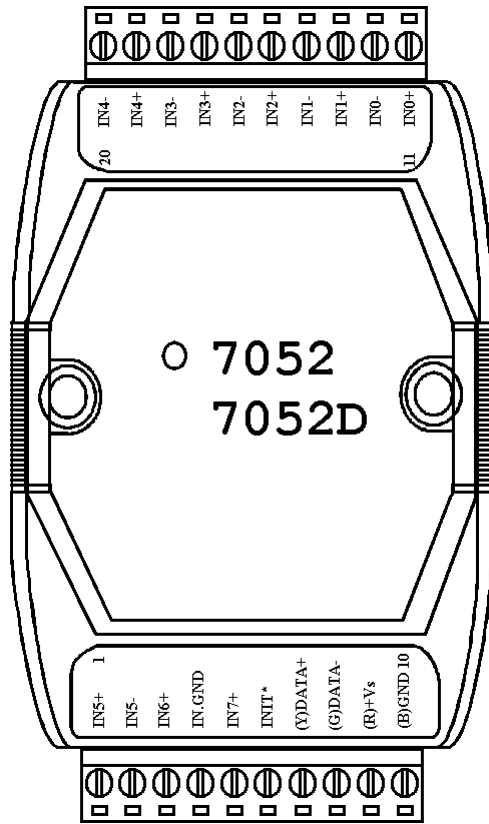
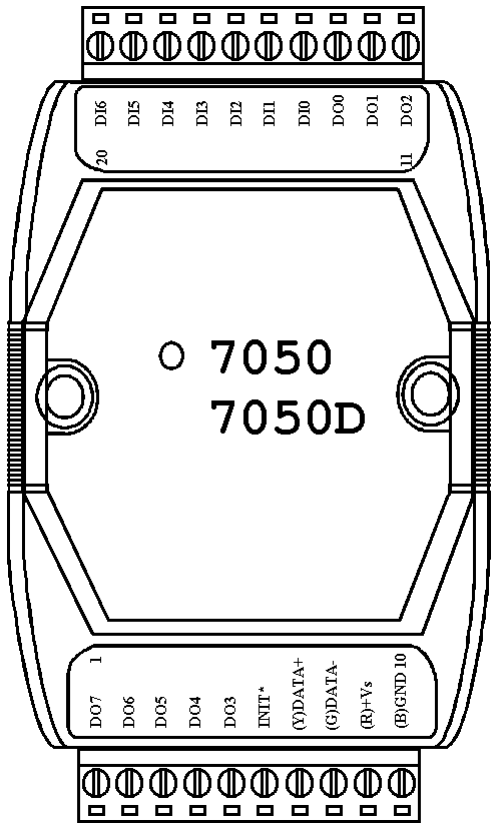

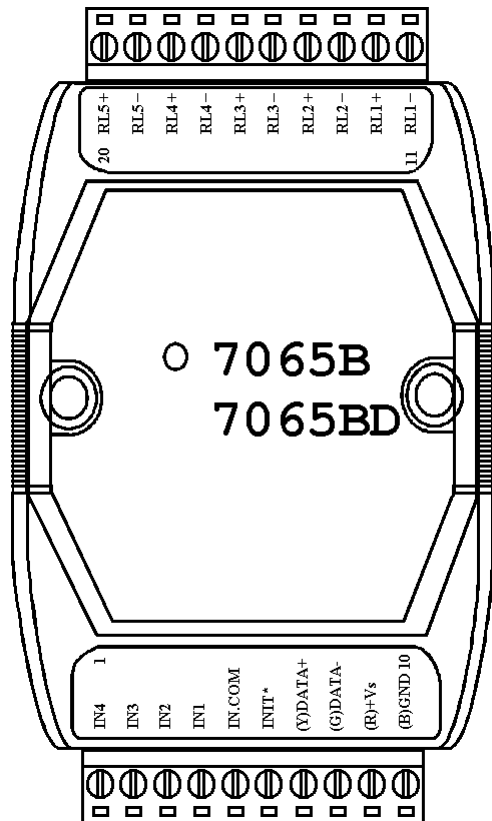
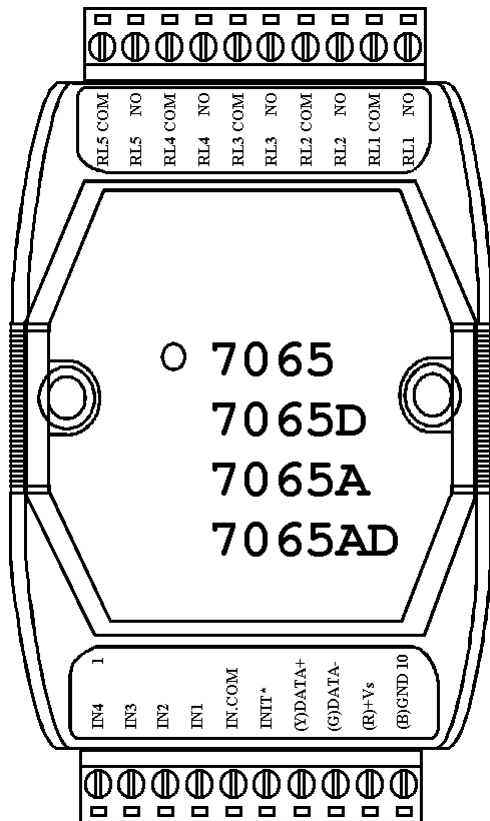
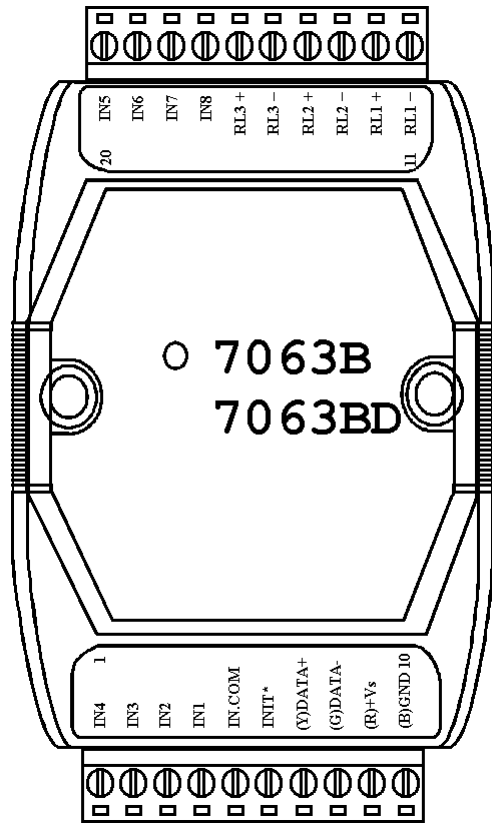
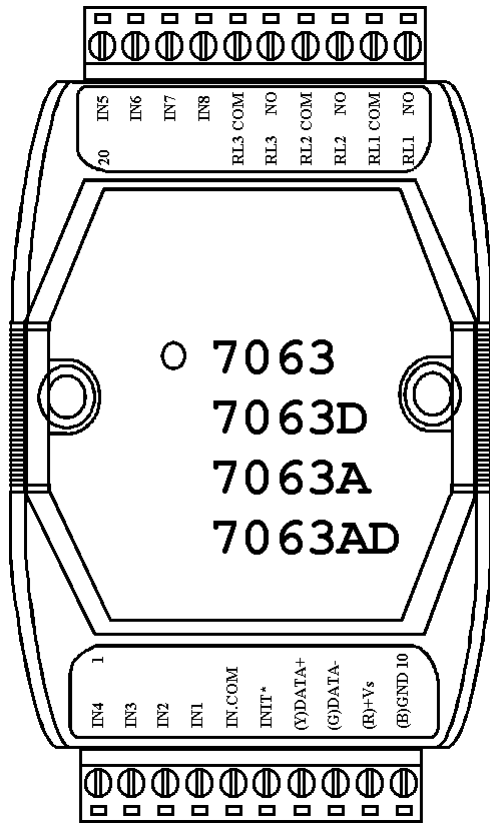

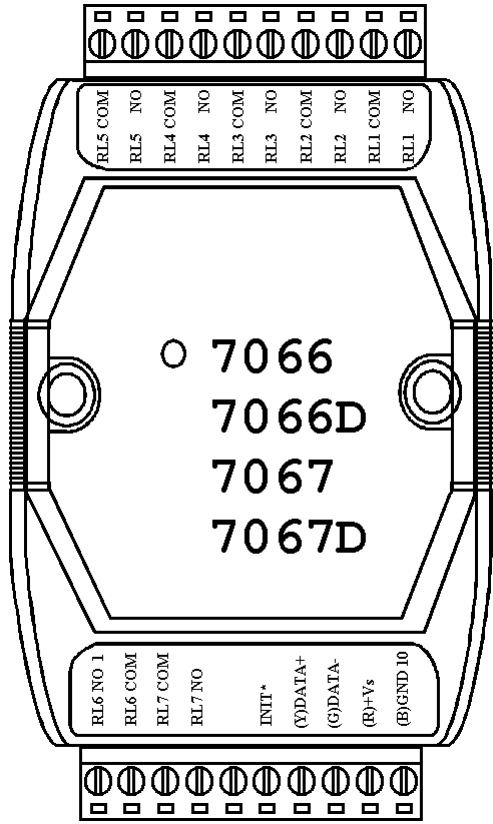

1.3 Specifications

Digital Input Modules			
	I-7041/41D	I-7052/52D	I-7053/53D
Input Channels	14	8	16
Isolation	Isolation with Common Source	6 differential and 2 common ground	Non-Isolated
Isolation Voltage	3750 Vrms	5000 Vrms	Non-Isolated
Digital Level 0	+1V max	+1V max	+2V max
Digital Level 1	+4 to +30 V	+4 to +30 V	+4 to +30 V
Input Impedance	3K ohms	3K ohms	820 ohms
Power Input	+10 to +30 VDC		
Power Consumption	0.2W(I-7041) 0.9W(I-7041D)	0.2W(I-7052) 0.6W(I-7052D)	0.7W(I-7053) 0.9W(I-7053D)

PhotoMOS Output Module	
	I-7066/66D
Output Channels	7
Load Current	0.13A
Load Voltage	350V max
Isolation Voltage	5000VAC
TurnOn Time	0.7mS typ
TurnOff Time	0.05mS typ
Power Input	+10 to +30 VDC
Power Consumption	0.5W(I-7066) 0.8W(I-7066D)

Open Collector Output Modules				
	I-7042 I-7042D	I-7043 I-7043D	I-7044 I-7044D	I-7050 I-7050D
Output Channels	13	16	8	8
Isolation	Isolation with Common Power	Non-Isola- tion	Isolation with Common Power	Non-Isola- tion
Isolation Voltage	3750 Vrms		3750 Vrms	
Load Voltage	Max +30V			
Max Load Current	100mA		375mA	30mA
Input Channels	No-Inputs		4	7
Isolation			Isolation with Common Source	Non-Isola- tion
Isolation Voltage			3750 Vrms	
Digital Level 0			1V max	1V max
Digital Level 1			4 to 30V	3.5 to 30V
Input Impedance			3K ohms	
Power Input			+10 to +30 VDC	
Power Consumption	1.0W (I-7042) 1.7W (I-7042D)	0.4W (I-7043) 1.1W (I-7043D)	1.0W (I-7044) 1.7W (I-7044D)	0.4W (I-7050) 1.1W (I-7050D)

Relay Output Modules				
	I-7060 I-7060D	I-7063 I-7063D	I-7065 I-7065D	I-7067 I-7067D
Output Channels	4	3	5	7
Relay Type	RL1, RL2 : Form A RL3, RL4 : Form C	Form A	Form A	Form A
Contact Rating	0.6A @125VAC 2A @30VDC	5A@250VAC 5A@30VDC		0.5A @120VAC 1.0A @24VDC
Surge Strength	500V	4000V		1500V
Operate Time	3mS	6mS Max.		5mS Max.
Release Time	2mS	3mS Max.		2mS Max.
Min. Life	5*10 ⁵ ops.	10 ⁵ ops.		10 ⁵ ops.
Input Channels	4	8	4	No input
Isolation	Isolation with Common Source			
Isolation Voltage	3750Vrms			
Digital Level 0	+1V max			
Digital Level 1	+4 to +30 V			
Input Impedance	3K ohms			
Power Input	+10 to +30 VDC			
Power Consumption	1.3W (I-7060) 1.9W (I-7060D)	1.0W (I-7063) 1.5W (I-7063D)	1.3W (I-7065) 2.2W (I-7065D)	1.5W (I-7067) 2.2W (I-7067D)

Solid-State Relay Output Modules				
	I-7063A I-7063AD	I-7065A I-7065AD	I-7063B I-7063BD	I-7065B I-7065BD
Output Channels	3	5	3	5
SSR Type	AC-SSR, Normal Open		DC-SSR, Normal Open	
Load Voltage Range	24 to 265 Vrms		3 to 30 VDC	
Leakage Current	1.5 mArms		0.1 mA	
Max Load Current	1.0 Arms		1.0 A	
Min. Operate Time	1mS			
Min. Release Time	1/2 cycle + 1mS		1mS	
Dielectric Strength	2500 Vrms			
Input Channels	8	4	8	4
Isolation	Isolation with Common Source			
Isolation Voltage	3750Vrms			
Digital Level 0	+1V max			
Digital Level 1	+4 to +30 V			
Input Impedance	3K ohms			
Power Input	+10 to +30 VDC			
Power Consumption	0.7W (I-7063A) 1.5W (I-7063AD)	0.8W (I-7065A) 1.6W (I-7065AD)	0.6W (I-7063B) 1.4W (I-7063BD)	0.7W (I-7065B) 1.5W (I-7065BD)

1.4 Block Diagram

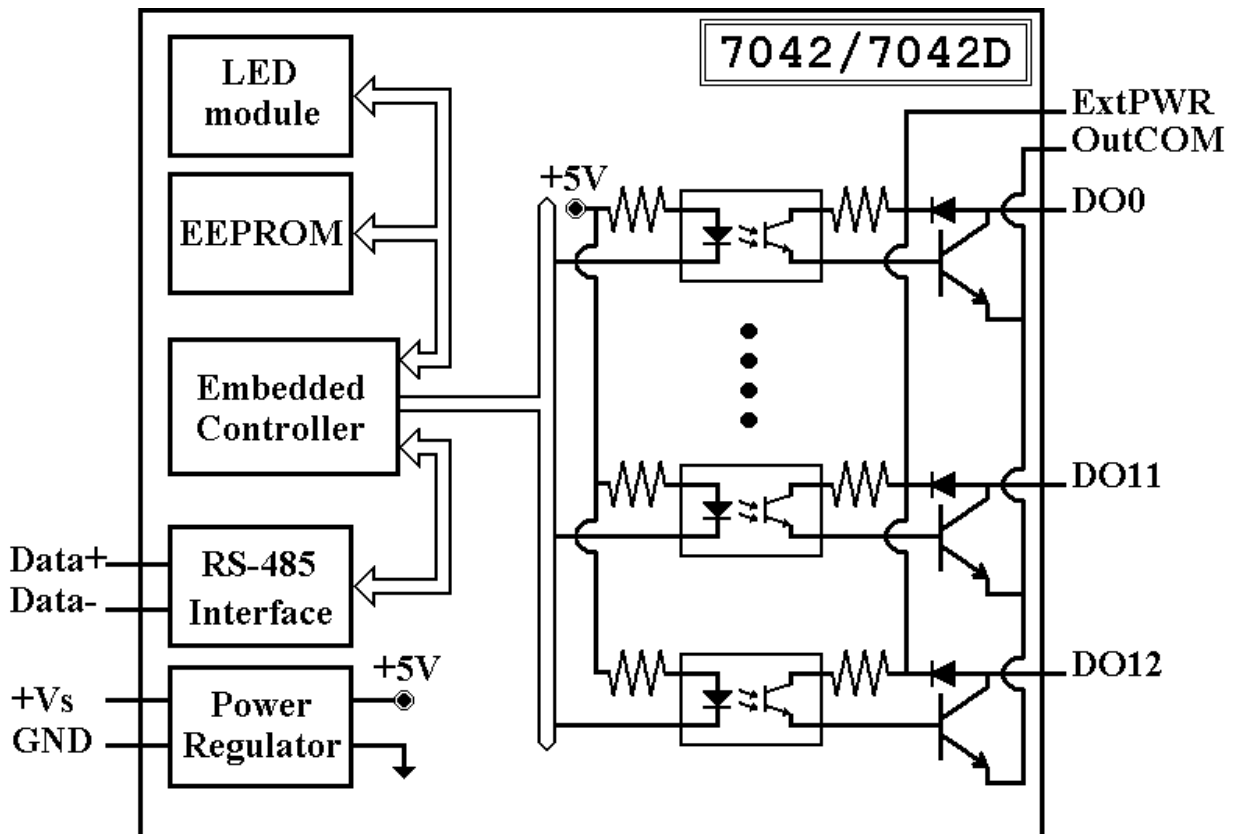
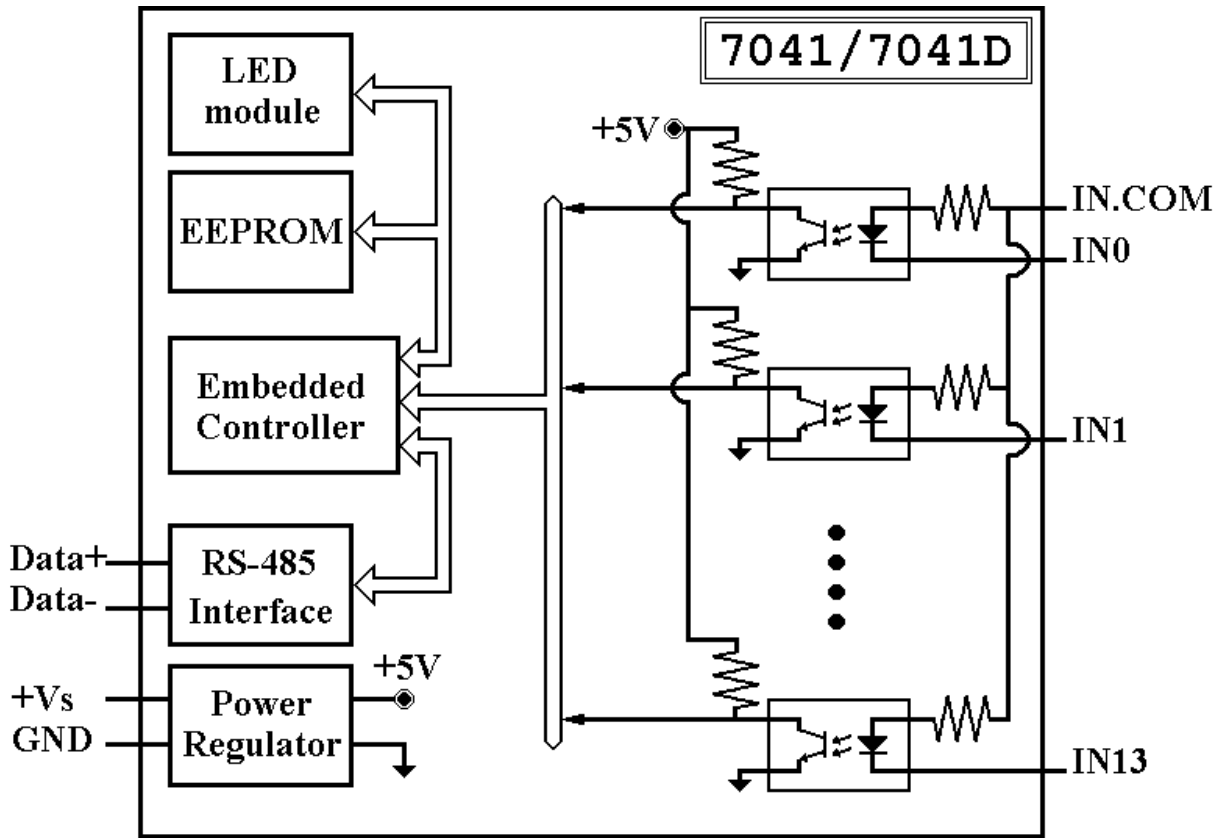

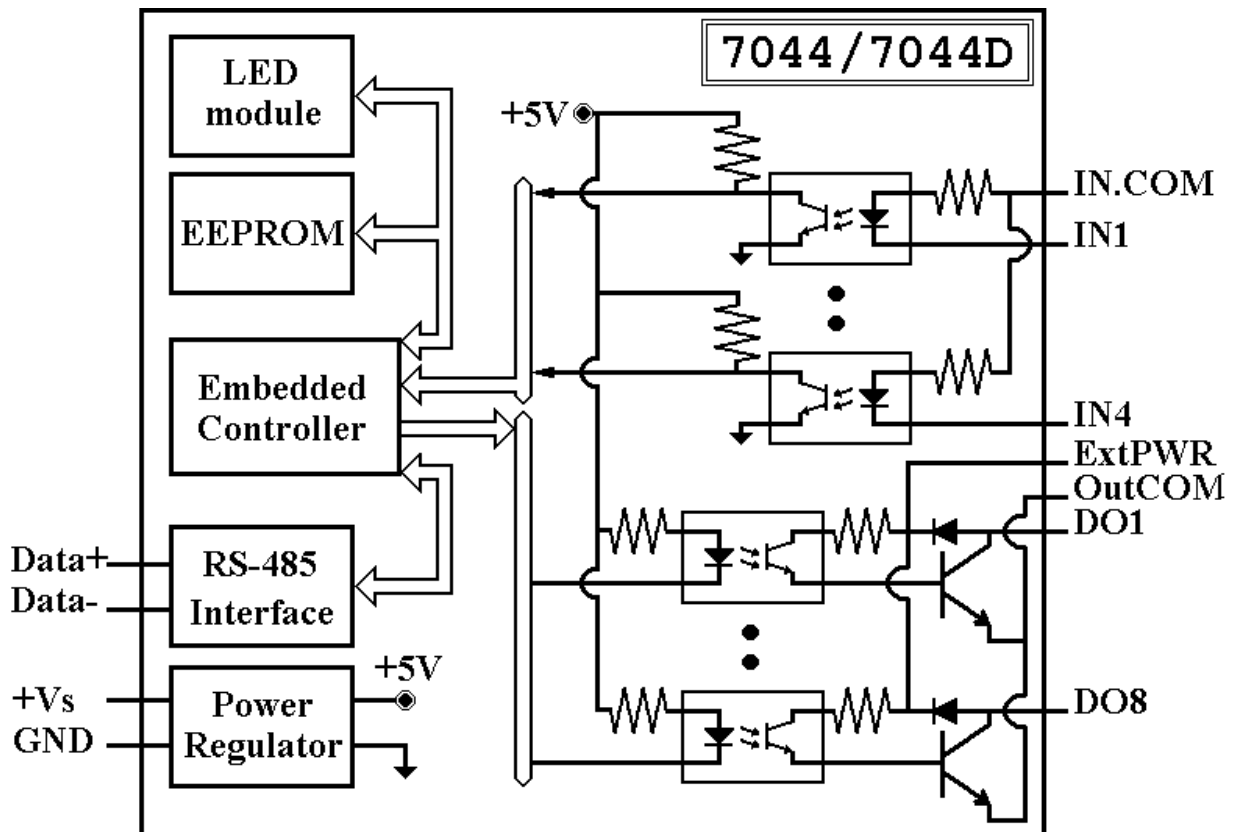
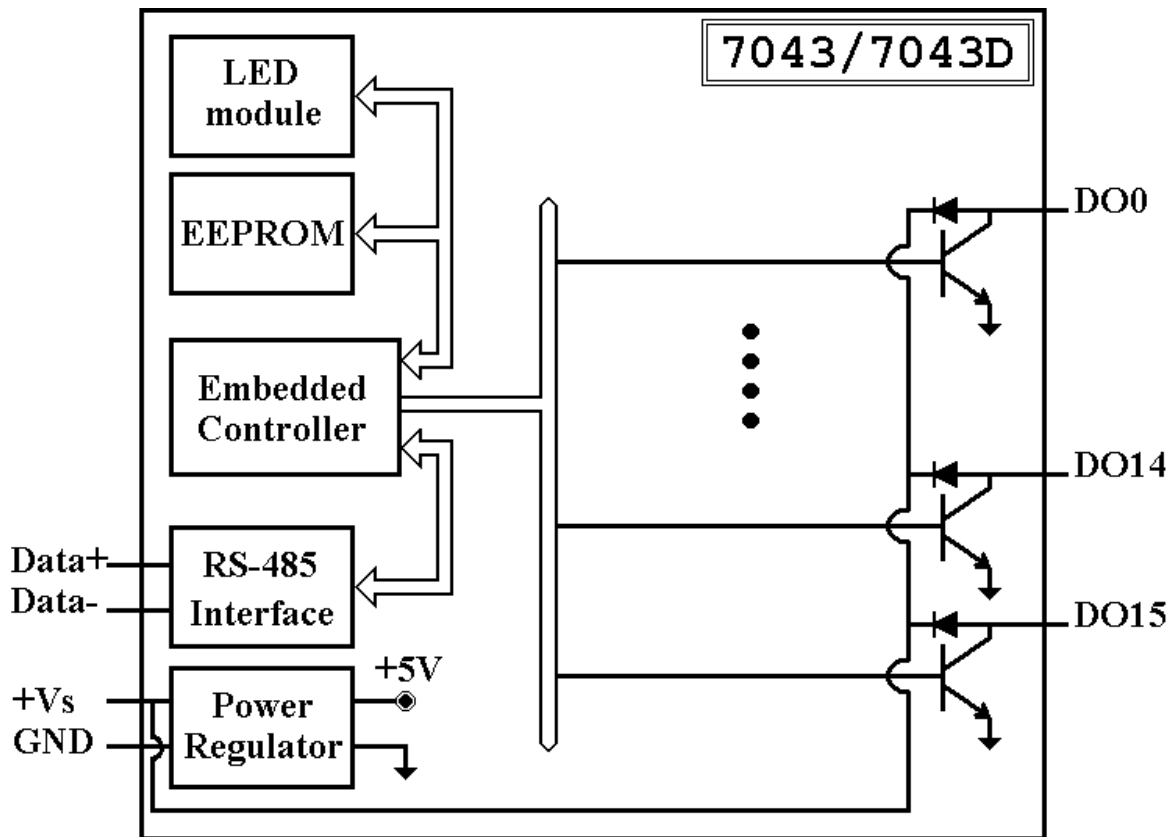

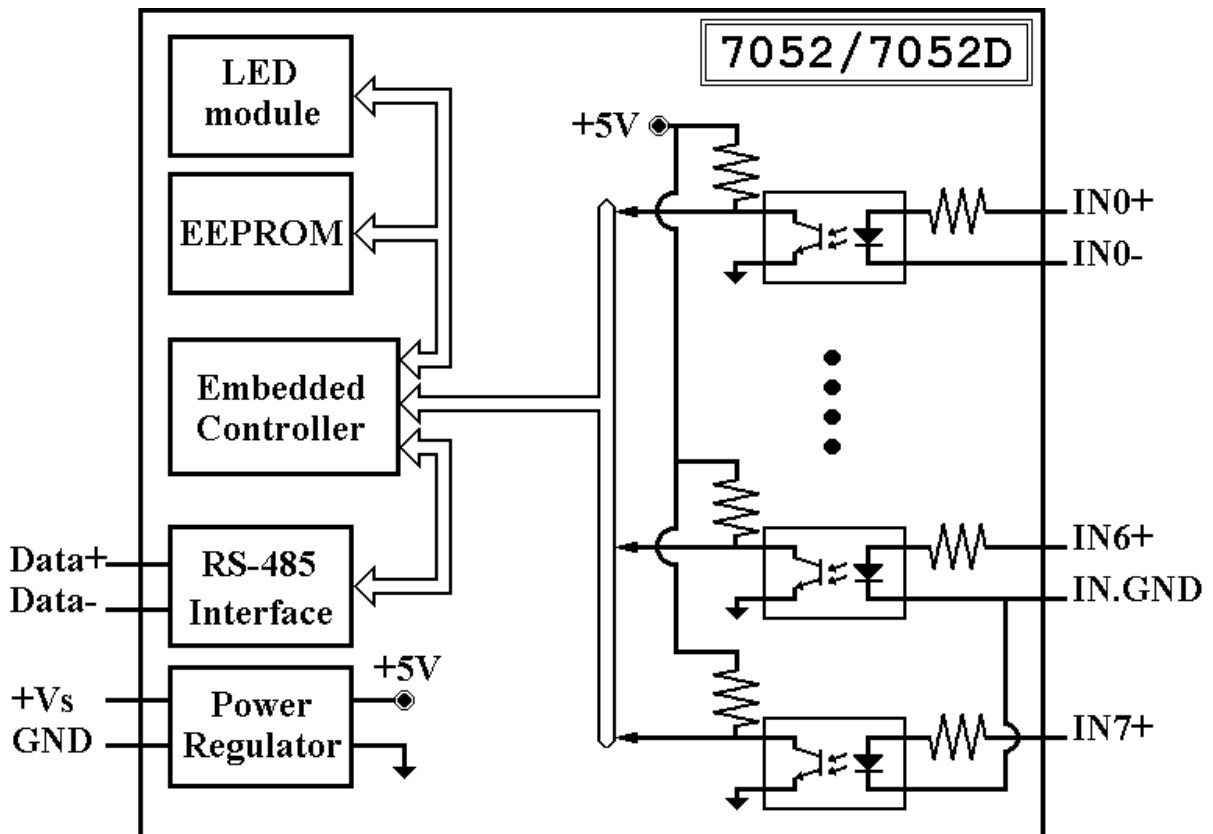
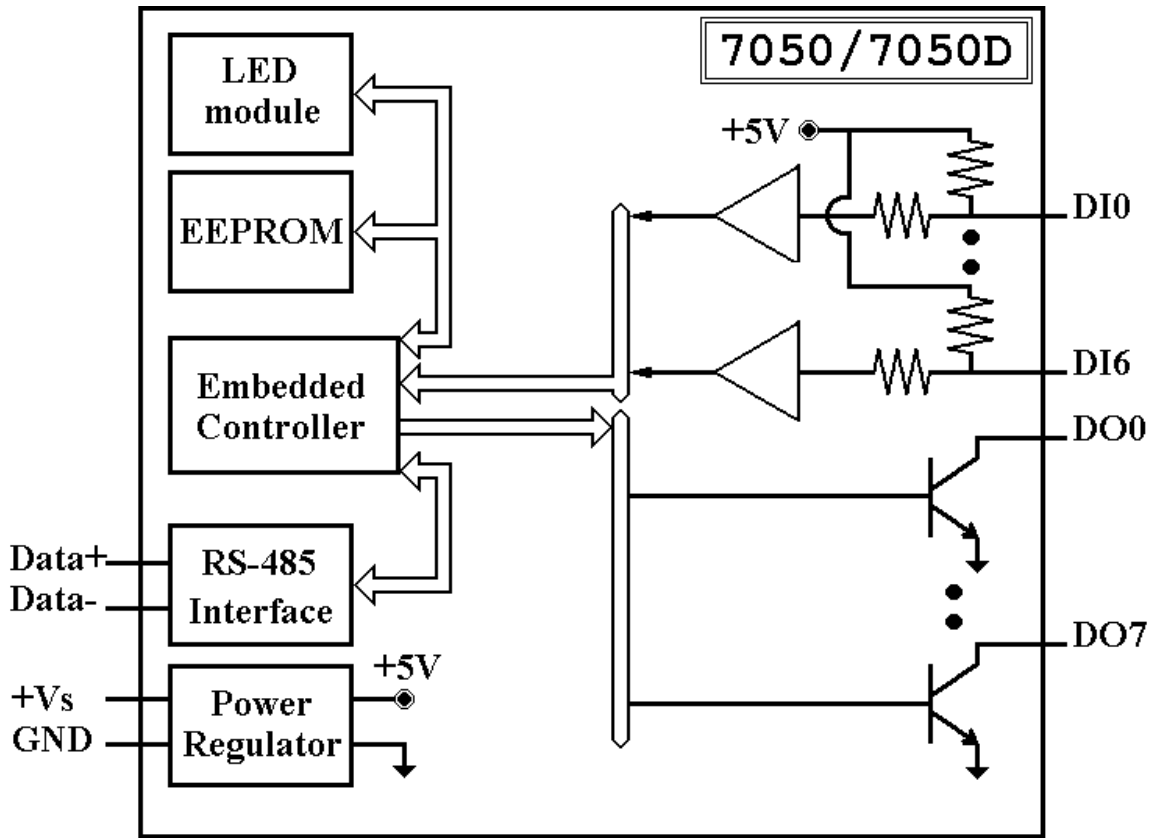

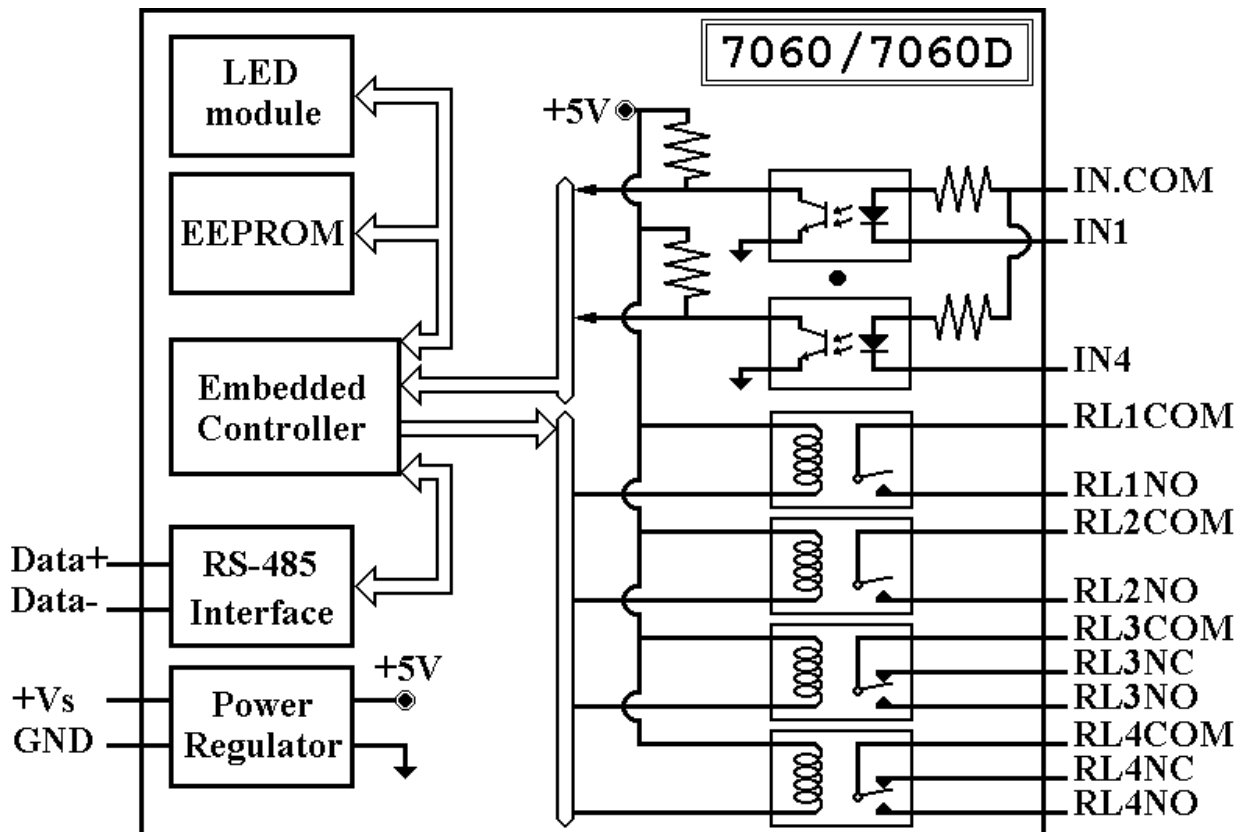
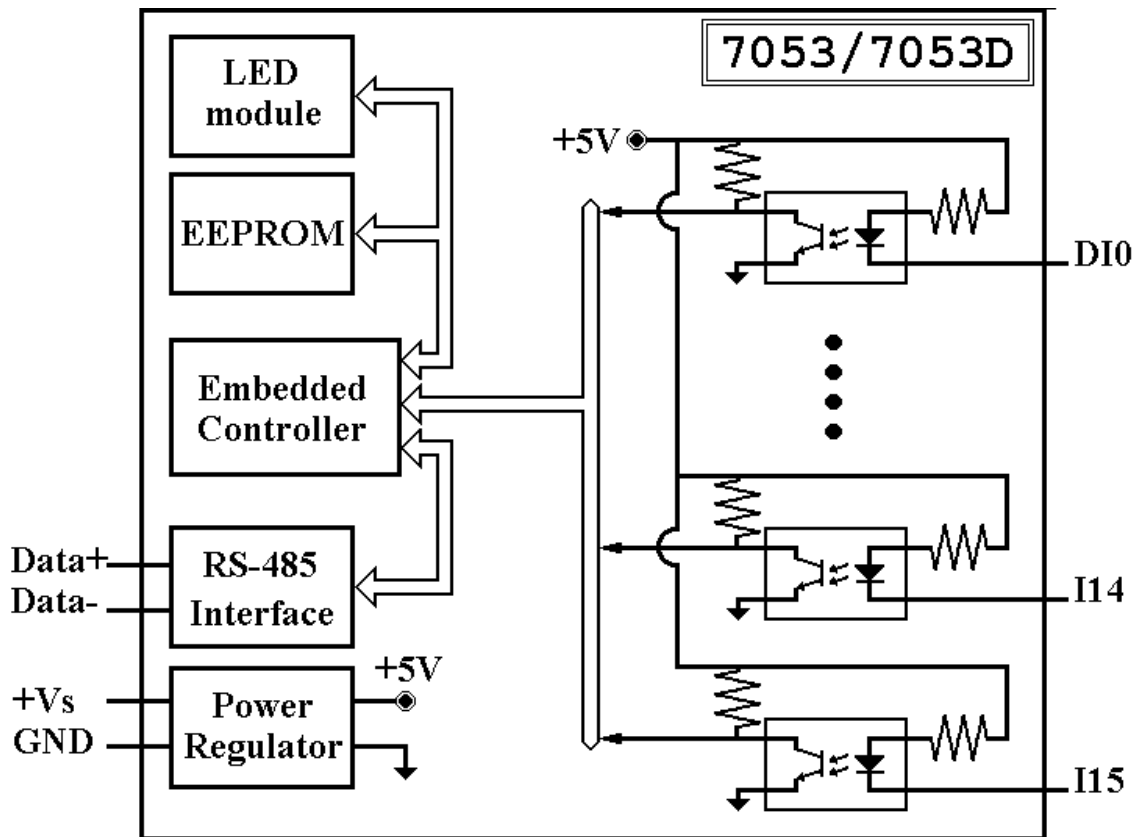

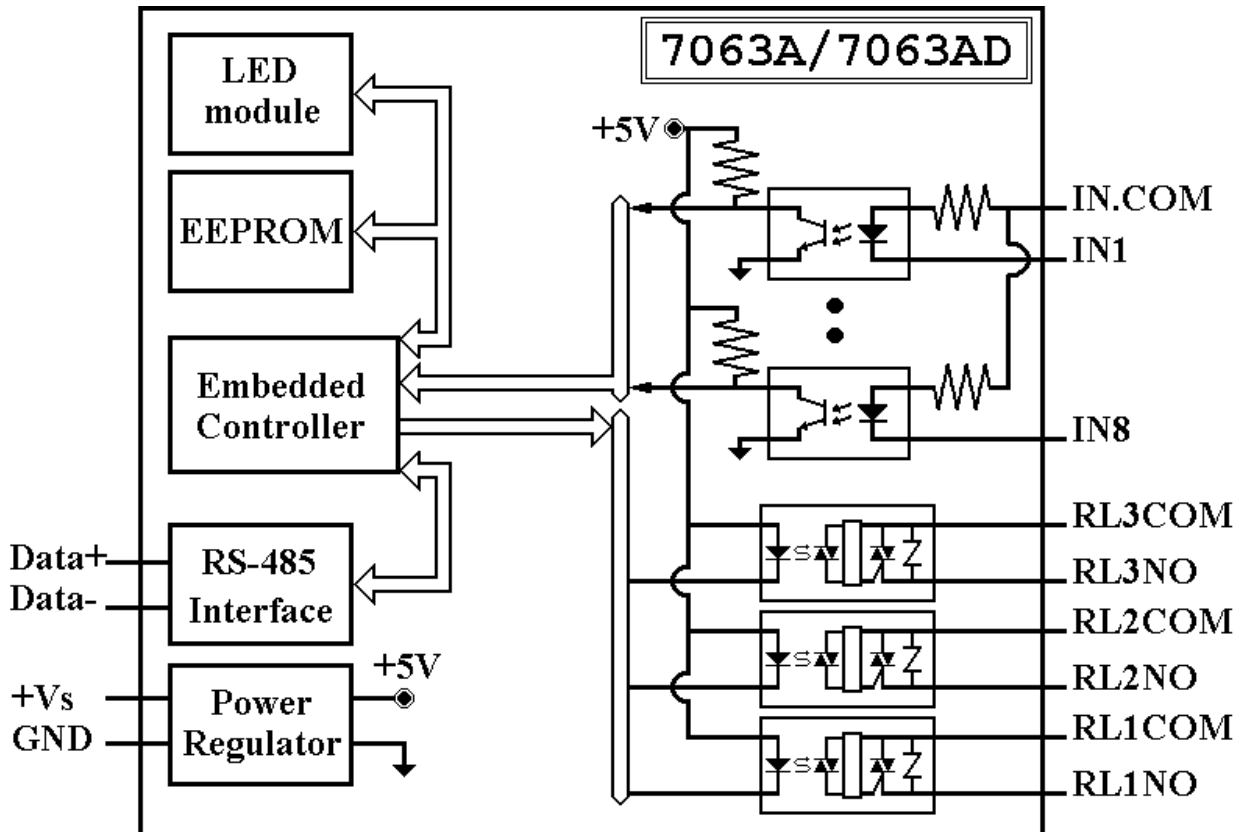
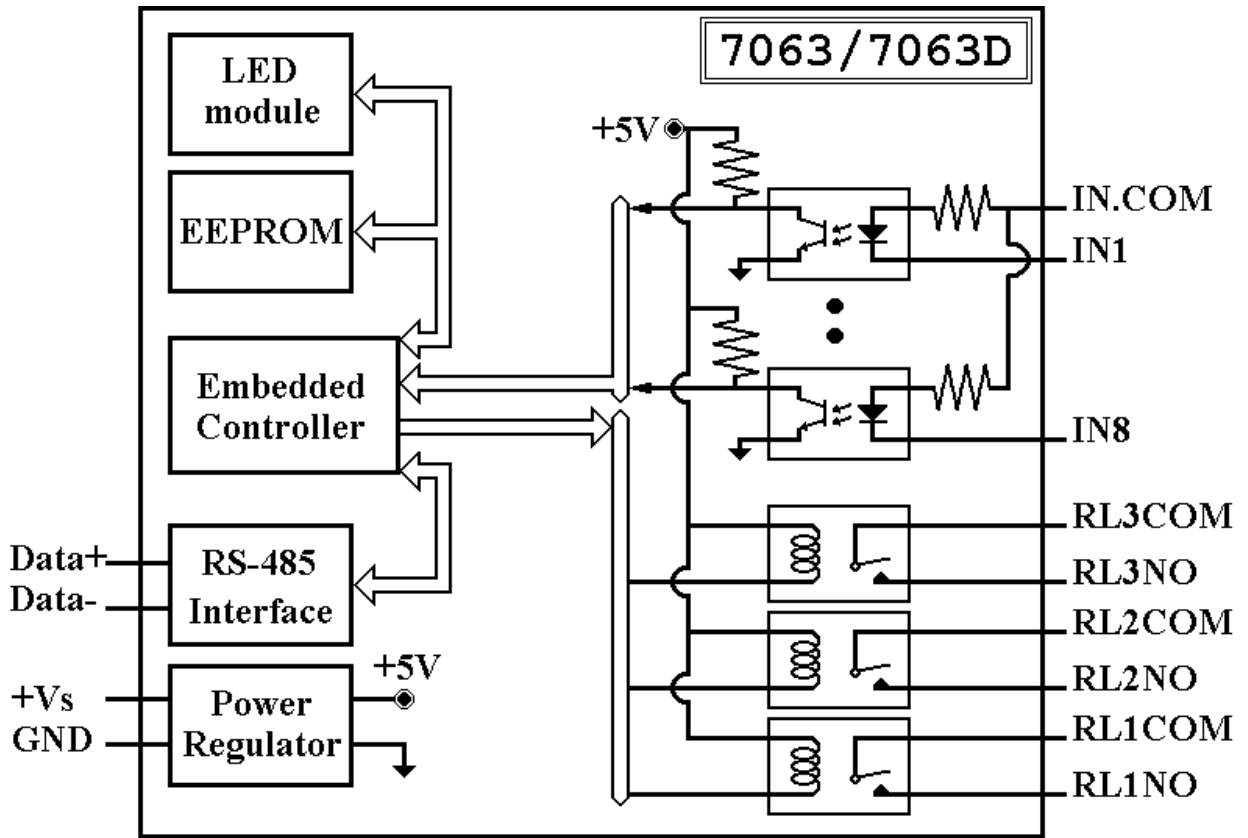

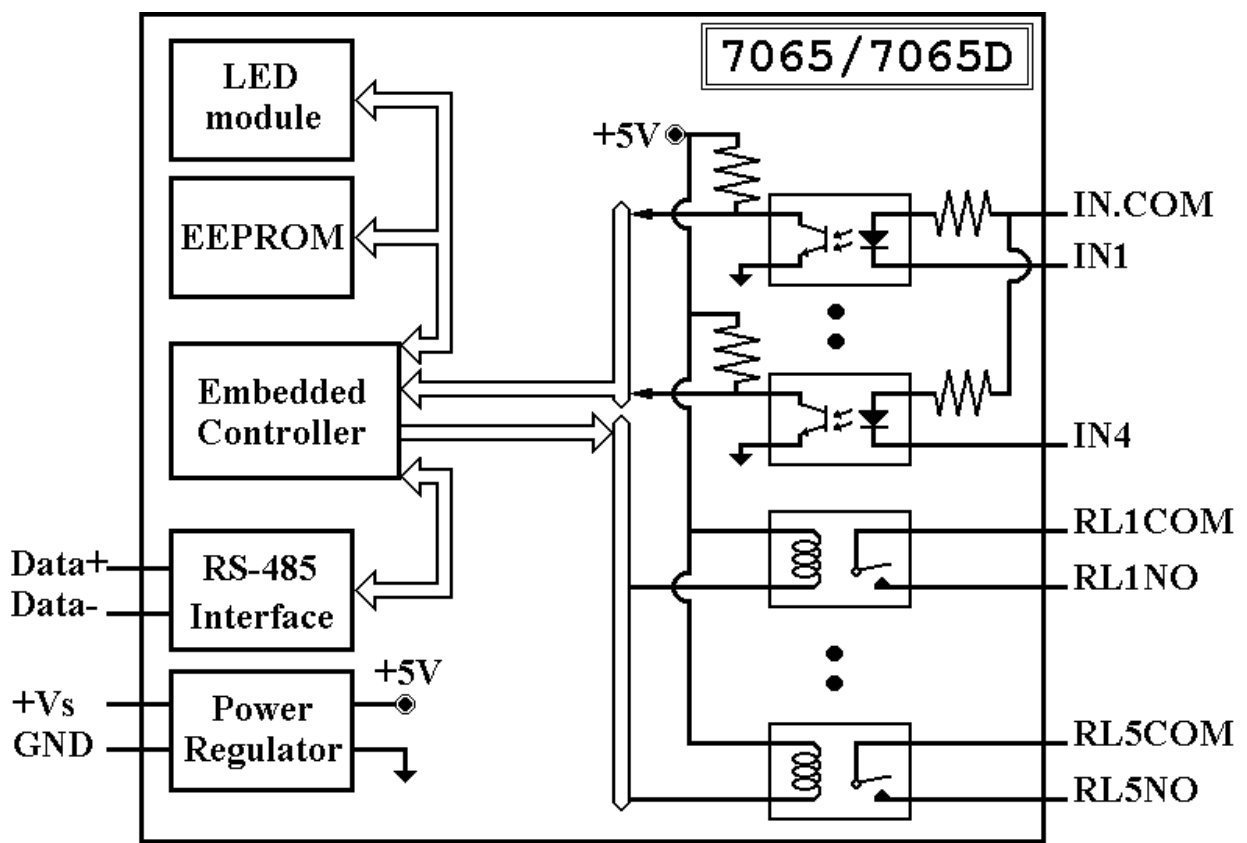
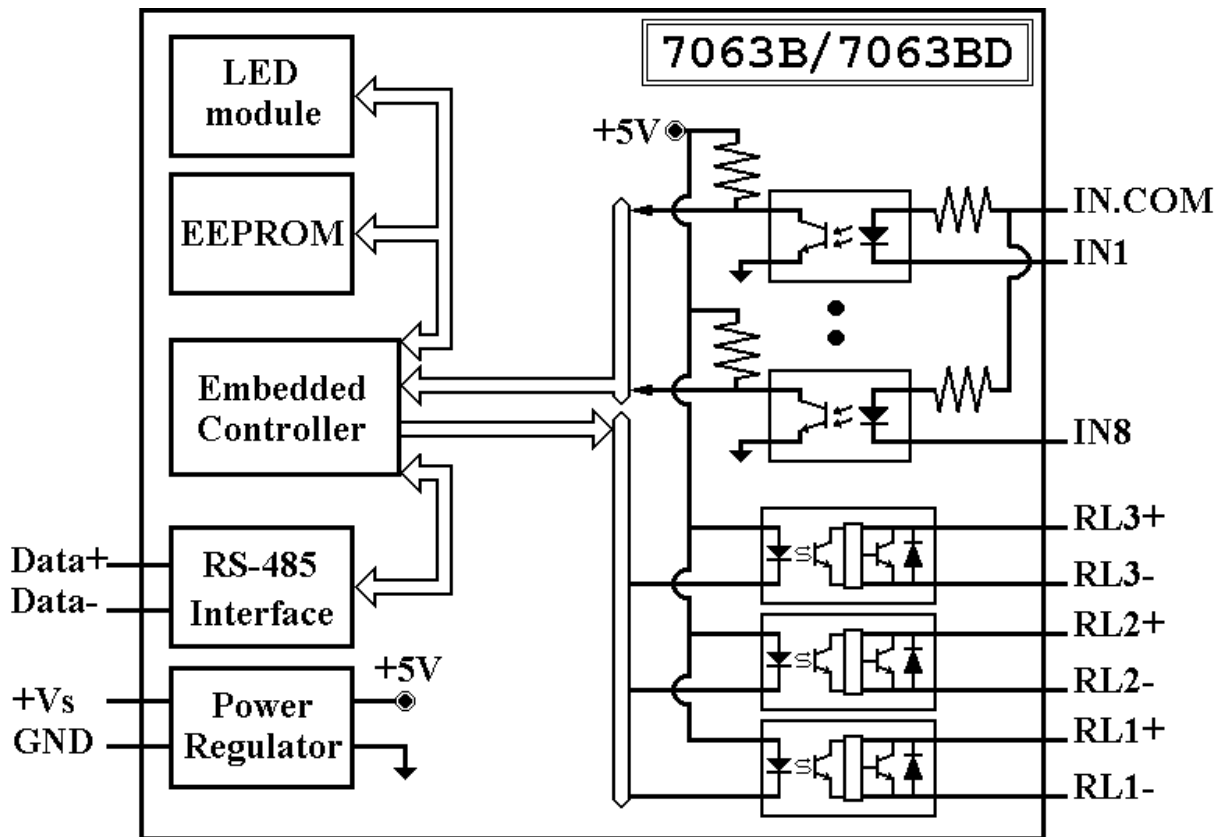

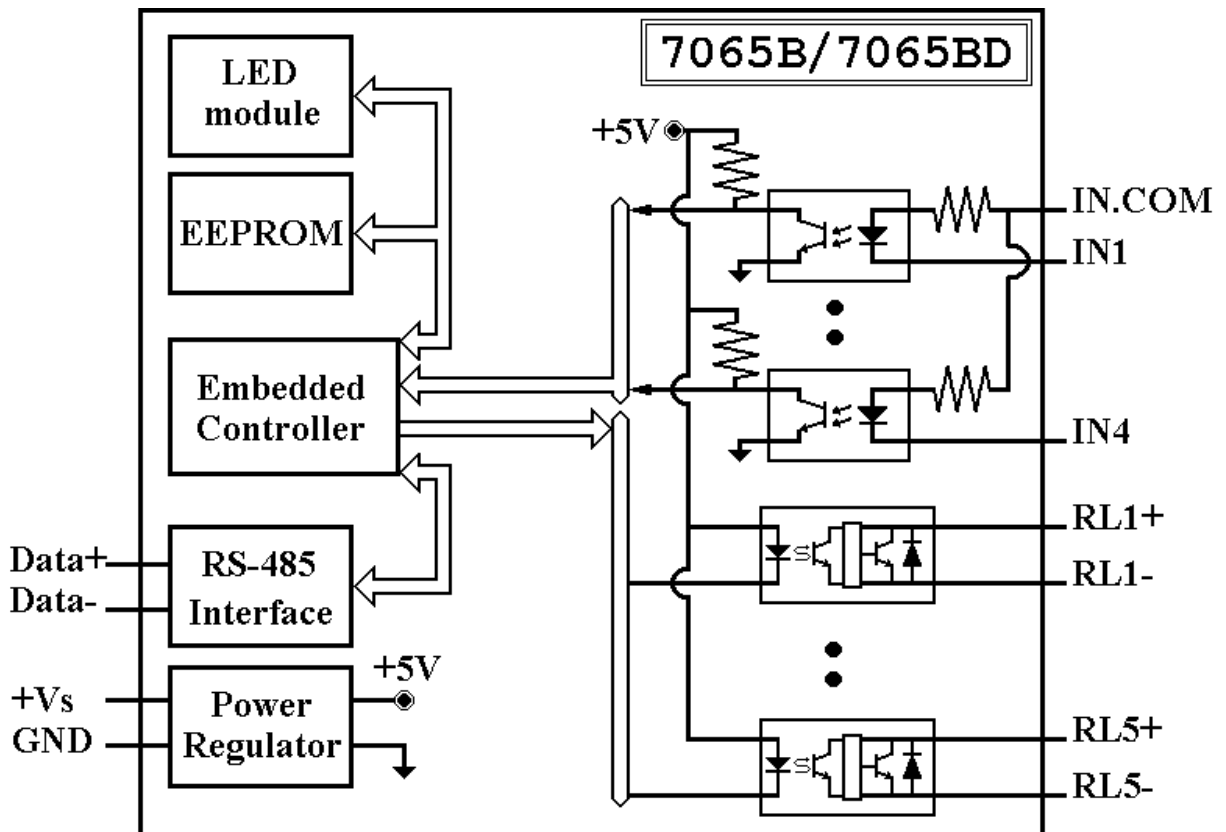
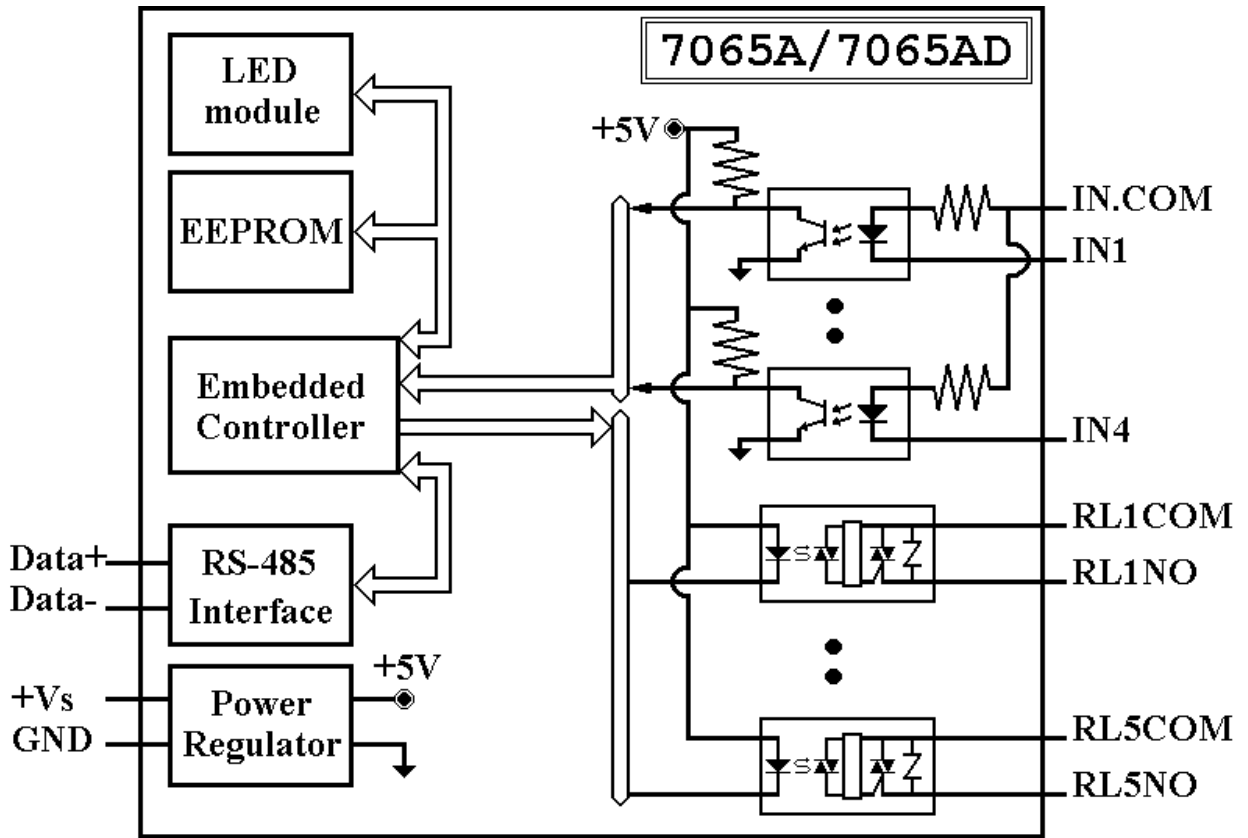

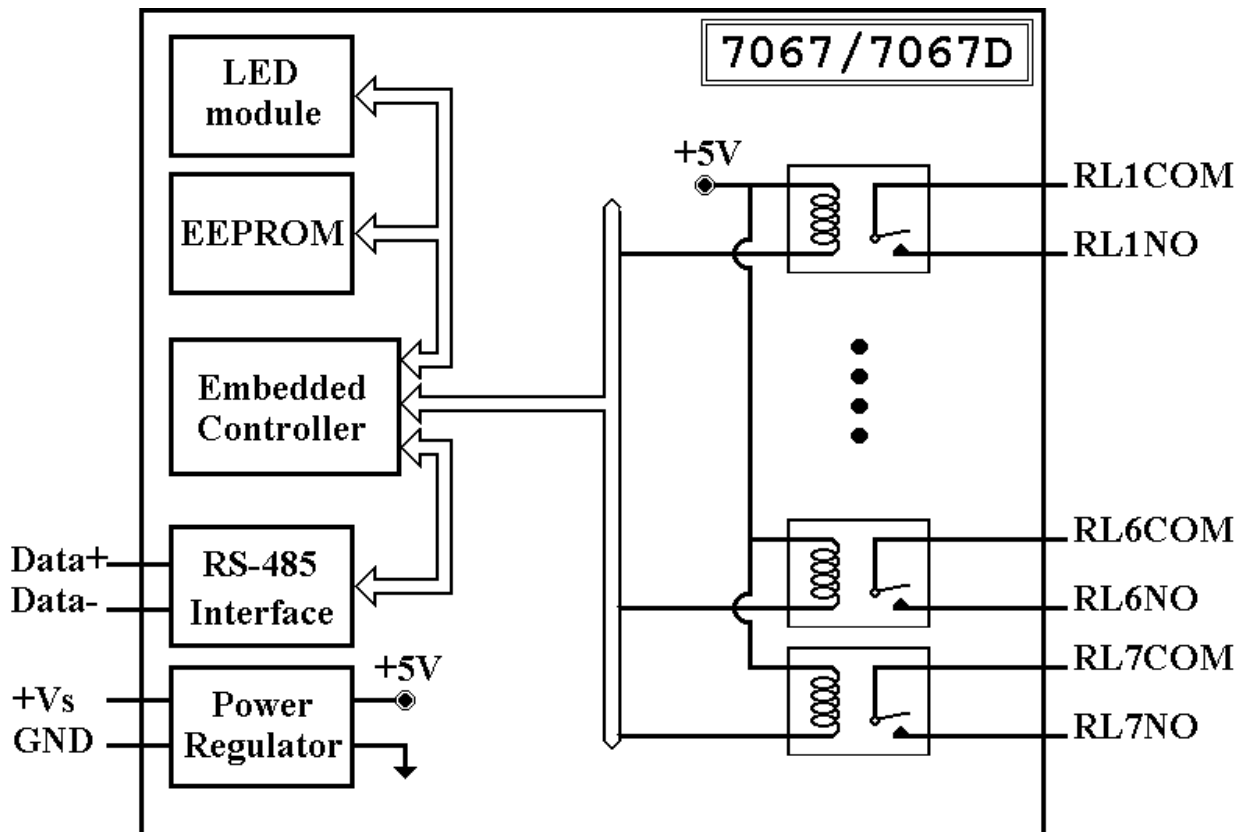
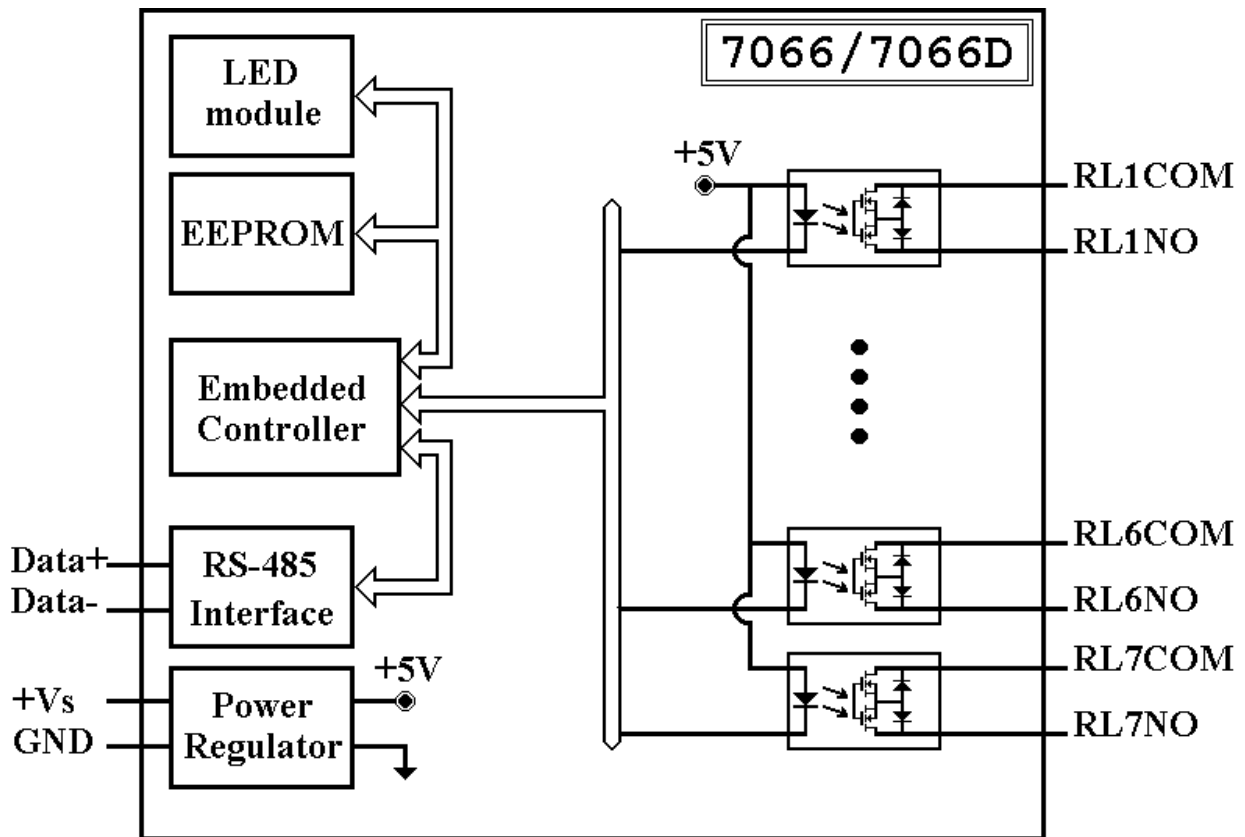

1.5 Wire Connection

Dry Contact signal input

I-7052/52D

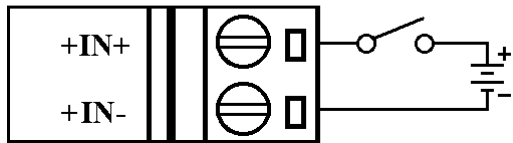
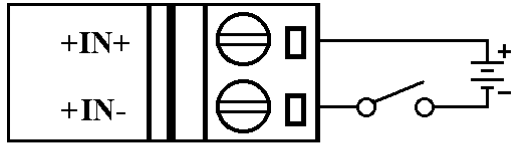

TTL/CMOS signal input

I-7052/52D

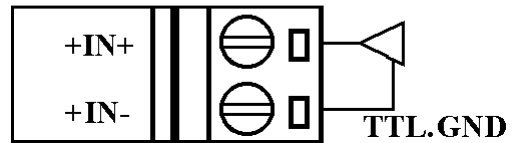
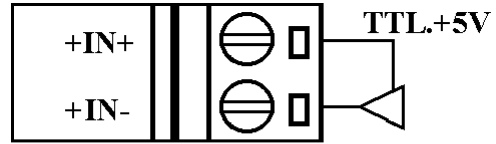

I-7050/50D/53/53D

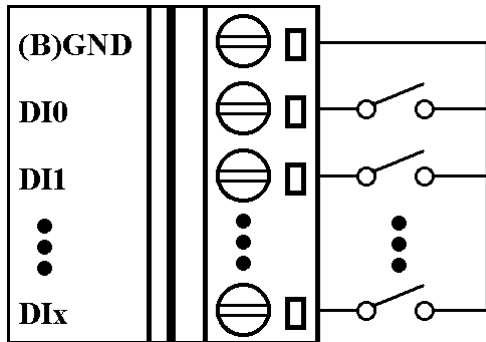

I-7050/50D/53/53D

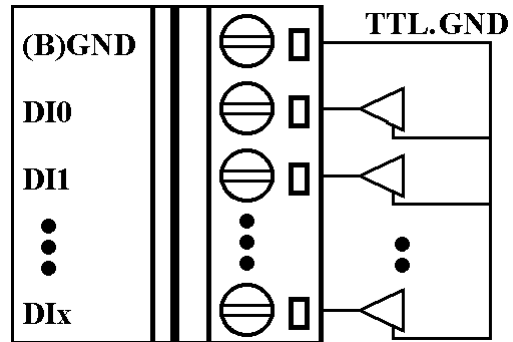

I-7041/41D/44/44D/60/60D/63/
63D/63A/63AD/63B/63BD/65/
65D/65A/65AD/65B/65BD

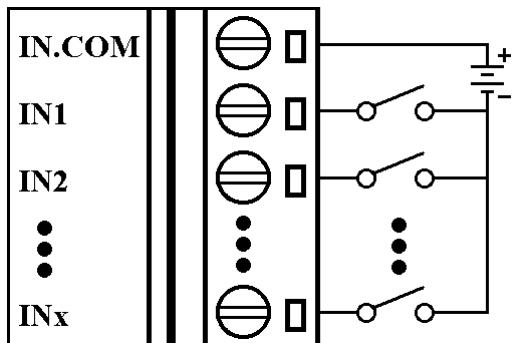

I-7041/41D/44/44D/60/60D/63/
63D/63A/63AD/63B/63BD/65/
65D/65A/65AD/65B/65BD

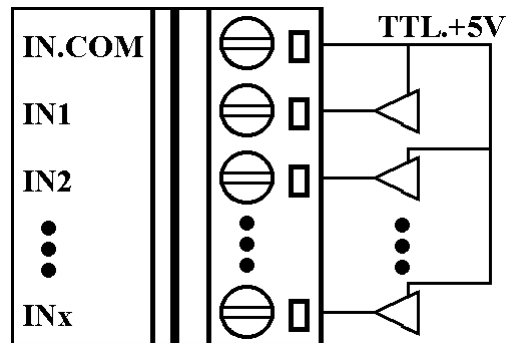

Open Collector signal input

I-7052/52D

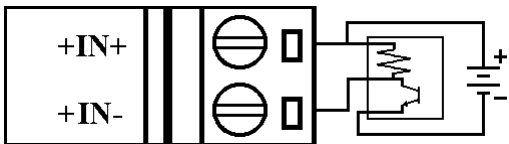
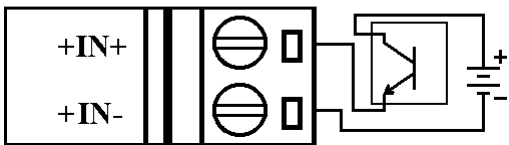
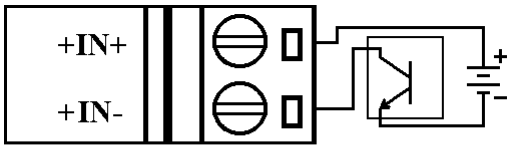

I-7050/50D/53/53D

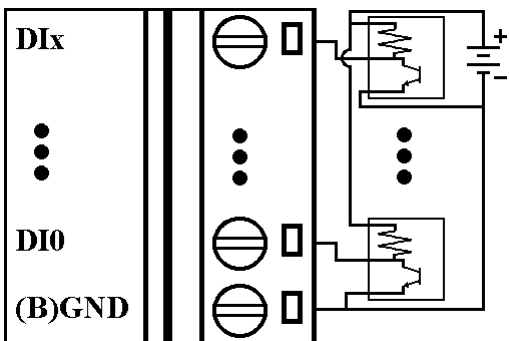
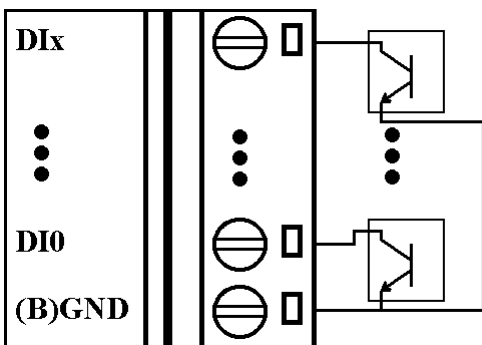

I-7041/41D/44/44D/60/60D/63/
63D/63A/63AD/63B/63BD/65/
65D/65A/65AD/65B/65BD

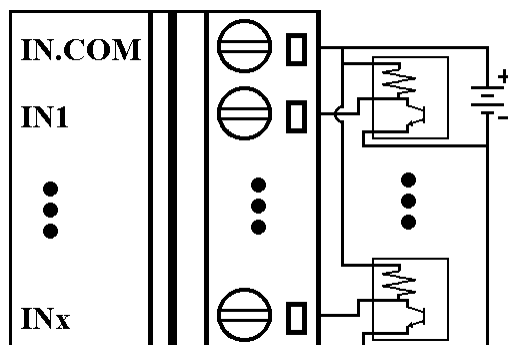
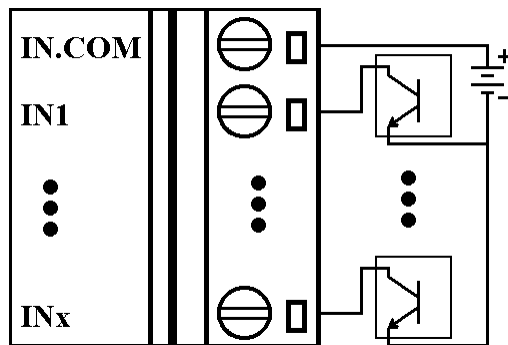

Open Collector output

I-7050/50D

Note : while connect inductive load(for example to drive relay), the diode is needed for prevent the counter EMF.

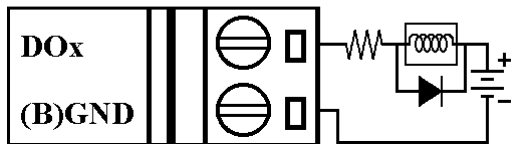
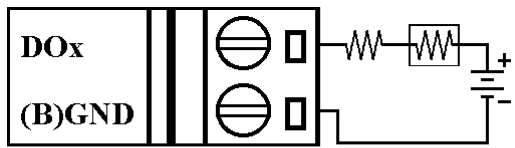

I-7043/43D

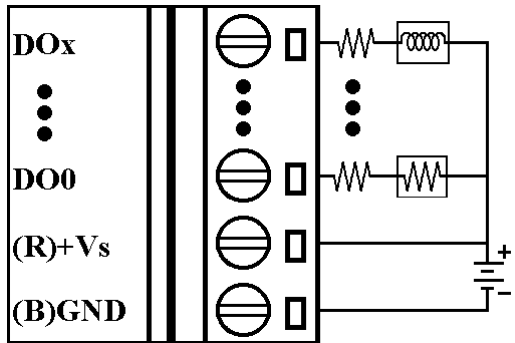

I-7042/42D/44/44D

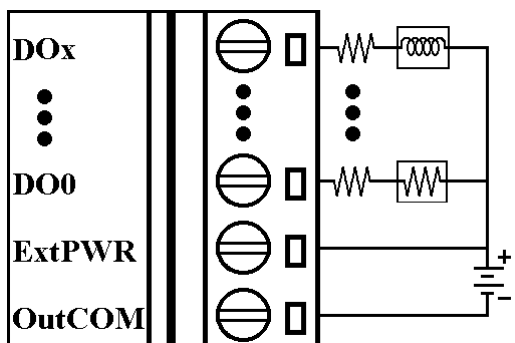

1.6 Quick Start

Refer to “I-7000 Bus Converter User Manual” and “Getting Start” for detail.

1.7 Default Setting

Default setting for I-7000 DIO modules :

- Address : 01
- Baudrate : 9600 bps
- Type : Type 40 for DIO mode
- Checksum Disable
- I-7043/43D jumper setting at DO15
- I-7053/53D jumper setting at DI15

1.8 Jumper Setting

I-7043/43D : Jumper J3 for select the pin INIT*/DO15

Select DO15 DO15  INIT*

Select INIT* DO15  INIT*

I-7053/53D : Jumper J1 for select the pin INIT*/DI15

Select DI15 DI15  INIT*

Select INIT* DI15  INIT*

1.9 Configuration Tables

Configuration Table of I-7000 DIO modules

Baudrate Setting (CC)

Code	03	04	05	06	07	08	09	0A
Baudrate	1200	2400	4800	9600	19200	38400	57600	115200

Type Setting (TT)

Type = **40** for DIO mode

Data Format Setting (FF)

7	6	5	4	3	2	1	0
*1	*2	0	0	0	*3		

*1 : Counter Update Direction : 0=Falling Edge, 1=Rising Edge

*2 : Checksum Bit : 0=Disable, 1=Enable

*3 : 7050 = 0 (Bit[2.1.0] = 000), 7060 = 1 (Bit[2.1.0] = 001)

7052 = 2 (Bit[2.1.0] = 010), 7053 = 3 (Bit[2.1.0] = 011)

Read Digital Input/Output Data Format

Data of \$AA6,\$AA4,\$AALS : (First Data)(Second Data)00

Data of @AA : (First Data)(Second Data)

	First Data		Second Data	
I-7041/41D	DI(8-13)	00 to 3F	DI(0-7)	00 to FF
I-7042/42D	DO(8-12)	00 to 1F	DO(0-7)	00 to FF
I-7043/43D	DO(8-15)	00 to FF	DO(0-7)	00 to FF
I-7044/44D	DO(1-8)	00 to FF	DI(1-4)	00 to 0F
I-7050/50D	DO(0-7)	00 to FF	DI(0-6)	00 to 7F
I-7052/52D	DI(0-7)	00 to FF	00	00
I-7053/53D	DI(8-15)	00 to FF	DI(0-7)	00 to FF
I-7060/60D	DO(1-4)	00 to 0F	DI(1-4)	00 to 0F
I-7063s *1	DO(1-3)	00 to 07	DI(1-8)	00 to FF
I-7065s *2	DO(1-5)	00 to 1F	DI(1-4)	00 to 0F
I-7066/66D	DO(1-7)	00 to 7F	00	00
I-7067/67D	DO(1-7)	00 to 7F	00	00
*1 I-7063s include : I-7063/63D/63A/63AD/63B/63BD				
*2 I-7065s include : I-7065/65D/65A/65AD/65B/65BD				

2. Command

Command Format : **(Leading)(Address)(Command)[CHK](cr)**

Response Format : **(Leading)(Address)(Data)[CHK](cr)**

[CHK] 2-character checksum

(cr) end-of-command character, character return(0x0D)

General Command Sets			
Command	Response	Description	Section
%AANNTTCCFF	!AA	Set Module Configuration	<i>Sec.2.1</i>
##**	No Response	Synchronized Sampling	<i>Sec.2.2</i>
#AABBDD	>	Digital Ouput	<i>Sec.2.3</i>
#AAN	!AA(Data)	Read Digital Input Counter	<i>Sec.2.4</i>
\$AA2	!AATTCCFF	Read Configuration	<i>Sec.2.5</i>
\$AA4	!S(Data)	Read Synchronized Data	<i>Sec.2.6</i>
\$AA5	!AAS	Read Reset Status	<i>Sec.2.7</i>
\$AA6	!(Data)	Read Digital I/O Status	<i>Sec.2.8</i>
\$AAF	!AA(Data)	Read Firmware Version	<i>Sec.2.9</i>
\$AAM	!AA(Data)	Read Module Name	<i>Sec.2.10</i>
\$AAC	!AA	Clear Latched Digital Input	<i>Sec.2.11</i>
\$AACN	!AA	Clear Ditial Input Count	<i>Sec.2.12</i>
\$AALS	!(Data)	Read Latched Digital Input	<i>Sec.2.13</i>
@AA	>(Data)	Read Digital Input	<i>Sec.2.14</i>
@AA(Data)	>	Set Digital Output	<i>Sec.2.15</i>
~AAO(Data)	!AA	Set Module Name	<i>Sec.2.16</i>

Host Watchdog Command Sets			
Command	Response	Description	Section
~**	No Response	Host OK	<i>Sec.2.17</i>
~AA0	!AASS	Read Module Status	<i>Sec.2.18</i>
~AA1	!AA	Reset Module Status	<i>Sec.2.19</i>
~AA2	!AAVV	Read Host Watchdog Timeout Value	<i>Sec.2.20</i>
~AA3EVV	!AA	Set Host Watchdog Timeout Value	<i>Sec.2.21</i>
~AA4V	!AA(Data)	Read PowerOn/Safe Value	<i>Sec.2.22</i>
~AA5V	!AA	Set PowerOn/Safe Value	<i>Sec.2.23</i>

2.1 %AANNTTCCFF

Description : Set module Configuration

Syntax : %AANNTTCCFF[CHK](cr)

% a delimiter character

AA address of setting module(00 to FF)

NN new address for setting module(00 to FF)

TT type 40 for DIO module

CC new baudrate for setting module (Ref *Sec.1.9*). It is needed to short the INIT* to ground while change baudrate. (Ref *Sec.3.1*)

FF new data format for setting module (Ref *Sec.1.9*). It is needed to short the INIT* to ground to change checksum setting. (Ref *Sec.3.1*)

Response : Valid Command : !AA[CHK](cr)

Invalid Command : ?AA[CHK](cr)

Syntax error or communication error may get no response.

! delimiter for valid command

? delimiter for invalid command

AA address of response module(00 to FF)

Example :

Command : %0102400600 Receive : !02

Set module address 01 to 02, return success.

Related Command :

Sec.2.5 \$AA2

Related Topics :

Sec.1.9 Configuration Tables, Sec.3.1 INIT pin Operation*

2.2 #**

Description : Synchronized Sampling

Syntax : #**[CHK](cr)

a delimiter character

** synchronized sampling command

Response : No response

Example :

Command : #** No response

Send synchronized sampling command to all modules.

Command : \$014 Receive : !10F0000

Read synchronized data from address 01, return S=1, first read and data

Command : \$014 Receive : !00F0000

Read synchronized data from address 02, return S=0, have readed and data.

Related Command :

Sec.2.6 \$AA4

2.3 #AABBDD

Description : Digital Output

Command : #AABBDD[CHK](cr)

delimiter character

AA address of reading module(00 to FF)

BBDD output command and parameter

For output multi-channel, the BB = 00, 0A or 0B the select which output group, and the DD is the output value.

Parameter for Multi-Channel Output					
	Output Channels	DD for command #AABBDD			
		BB=00/0A		BB=0B	
I-7042/42D	13	00 to FF	DO(0-7)	00 to 1F	DO(8-12)
I-7043/43D	16	00 to FF	DO(0-7)	00 to FF	DO(8-15)
I-7044/44D	8	00 to FF	DO(1-8)	NA	NA
I-7050/50D	8	00 to FF	DO(0-7)	NA	NA
I-7060/60D	4	00 to 0F	RL(1-4)	NA	NA
I-7063s ^{*1}	3	00 to 07	RL(1-3)	NA	NA
I-7065s ^{*2}	5	00 to 1F	RL(1-5)	NA	NA
I-7066/66D	7	00 to 7F	RL(1-7)	NA	NA
I-7067/67D	7	00 to 7F	RL(1-7)	NA	NA
*1 I-7063s include : I-7063/63D/63A/63AD/63B/63BD					
*2 I-7065s include : I-7065/65D/65A/65AD/65B/65BD					

For output single-channel, the BB = 1c, Ac or Bc where c is the selected channel, and the DD must be 00 to clear output and 01 to set output.

Parameter for Single-Channel Output				
	Single channel output command #AABBDD			
	c for BB=1c/Ac		c for BB=Bc	
I-7042/42D	0 to 7	DO(0-7)	0 to 4	DO(8-12)
I-7043/43D	0 to 7	DO(0-7)	0 to 7	DO(8-15)
I-7044/44D	0 to 7	DO(1-8)	NA	NA
I-7050/50D	0 to 7	DO(0-7)	NA	NA
I-7060/60D	0 to 3	RL(1-4)	NA	NA
I-7063s * ¹	0 to 2	RL(1-3)	NA	NA
I-7065s * ²	0 to 4	RL(1-5)	NA	NA
I-7066/66D	0 to 6	RL(1-7)	NA	NA
I-7067/67D	0 to 6	RL(1-7)	NA	NA
* ¹ I-7063s include : I-7063/63D/63A/63AD/63B/63BD				
* ² I-7065s include : I-7065/65D/65A/65AD/65B/65BD				

Response : Valid Command : >[CHK](cr)
Invalid Command : ?[CHK](cr)
Ignored Command : ![CHK](cr)
Syntax error or communication error may get no response.

> delimiter for valid command
? delimiter for invalid command
! delimiter for ignore the command. The module's host watchdog timeout status is set, and the output is set to Safe Value.

Example :

Command : #0100FF Receive : >

Assume module is I-7044, set address 01 output value FF, return success.

Command : #021001 Receive : >

Assume module is I-7067, set address 02 channel 0 on, return success.

Command : #021701 Receive : ?

Set address 02 channel 7 on, return the channel is invalid for I-7067 only have 7-channel outputs (0 to 6).

Command : #0300FF Receive : !

Set address 03 output value FF, return ignore. The module's host watchdog timeout status is set, and the output is set to Safe Value.

Related Command :

Sec.2.15 @AA(Data), Sec.2.18 ~AA0, Sec.2.19 ~AA1

Related Topics :

Sec.1.9 Configuration Tables, Sec.3.2 Module Status, Sec.3.3 Dual Watchdog Operation

Note :

The command is useless for I-7041/41D/52/52D/53/53D.

2.4 #AAN

Description : Read Digital Input Counter from channel N

Command : #AAN[CHK](cr)

delimiter character

AA address of reading module (00 to FF)

N channel to read

Response : Valid Command : !AA(Data)[CHK](cr)

Invalid Command : ?AA[CHK](cr)

Syntax error or communication error may get no response.

! delimiter for valid command

? delimiter for invalid command

AA address of response module(00 to FF)

(Data) digital input counter value in decimal, from 00000 to 65535

Example :

Command : #032 Receive : !0300103

Read address 03 digital input counter value of channel 2, return value 103.

Command : #025 Receive : ?02

Read address 02 digital input counter value of channel 5, return the channel is not available.

Related Command :

Sec.2.12 \$AACN

Note :

The command is useless for I-7042/42D/43/43D/66/66D/67/67D.

2.5 \$AA2

Description : Read Configuration

Command : \$AA2[CHK](cr)

\$ delimiter character

AA address of reading module (00 to FF)

2 command for read configuration

Response : Valid Command : !AATTCCFF[CHK](cr)

Invalid Command : ?AA[CHK](cr)

Syntax error or communication error may get no response.

! delimiter for valid command

? delimiter for invalid command

AA address of response module(00 to FF)

TT type code of module, it must be 40

CC baudrate code of module (Ref *Sec.1.9*)

FF data format of module (Ref *Sec.1.9*)

Example :

Command : \$012 Receive : !01400600

Read address 01 status, return DIO mode, baud 9600, no checksum.

Related Command :

Sec2.1 %AANNTTCCFF

Related Topics :

Sec.1.9 Configuration Tables, *Sec3.1* INIT* pin Operation

2.6 \$AA4

Description : Read Synchronized Data

Command : \$AA4[CHK](cr)

\$ delimiter character

AA address of reading module (00 to FF)

4 command for read synchronized data

Response : Valid Command : !S(Data)[CHK](cr)

Invalid Command : ?AA[CHK](cr)

Syntax error or communication error may get no response.

! delimiter for valid command

? delimiter for invalid command

AA address of response module(00 to FF)

S status of synchronized data, 1 = first read, 0 = been readed

(Data) synchronized DIO value (Ref *Sec.1.9*)

Example :

Command : \$014 Receive : ?01

Read address 01 synchronized data, return no data available.

Command : #** Receive : no response

Send synchronized sampling to all modules.

Command : \$014 Receive : !1000F00

Read address 01 synchronized data, return S=1, first read, and synchronized data 0F00

Related Command :

Sec2.2 #**

Related Topics :

Sec.1.9 Configuration Tables

2.7 \$AA5

Description : Read Reset Status

Command : \$AA5[CHK](cr)

\$ delimiter character

AA address of reading module (00 to FF)

5 command for read reset status

Response : Valid Command : !AAS[CHK](cr)

Invalid Command : ?AA[CHK](cr)

Syntax error or communication error may get no response.

! delimiter for valid command

? delimiter for invalid command

AA address of response module(00 to FF)

S reset status, 1 = the module is been reset, 0 = the module is not been reseted

Example :

Command : \$015 Receive : !011

Read address 01 reset status, return first read.

Command : \$015 Receive : !010

Read address 01 reset status, return no reset occurred.

Related Topics :

Sec3.4 Reset Status

2.8 \$AA6

Description : Read Digital I/O Status

Command : \$AA6[CHK](cr)

\$ delimiter character

AA address of reading module (00 to FF)

6 command for read digital input/output status

Response : Valid Command : **!(Data)[CHK](cr)**

Invalid Command : **?AA[CHK](cr)**

Syntax error or communication error may get no response.

! delimiter for valid command

? delimiter for invalid command

AA address of response module(00 to FF)

(Data) digital input/output value (Ref *Sec.1.9*)

Example :

Command : \$016 Receive : !0F0000

Assume module is I-7060, read address 01 DIO status, return 0F00, digital input IN1 to IN4 are open, digital output RL1 to RL4 are off.

Related Command :

Sec.2.14 @AA

Related Topics :

Sec1.9 Configuration Tables

2.9 \$AAF

Description : Read Firmware Version

Command : \$AAF[CHK](cr)

\$ delimiter character

AA address of reading module (00 to FF)

F command for read firmware version

Response : Valid Command : !AA(Data)[CHK](cr)

Invalid Command : ?AA[CHK](cr)

Syntax error or communication error may get no response.

! delimiter for valid command

? delimiter for invalid command

AA address of response module(00 to FF)

(Data) firmware version of module

Example :

Command : \$01F Receive : !01A2.0

Read address 01 firmware version, return version A2.0.

Command : \$02F Receive : !01B1.1

Read address 01 firmware version, return version B1.1.

2.10 \$AAM

Description : Read Module Name

Command : \$AAM[CHK](cr)

\$ delimiter character

AA address of reading module (00 to FF)

M command for read module name

Response : Valid Command : !AA(Data)[CHK](cr)

Invalid Command : ?AA[CHK](cr)

Syntax error or communication error may get no response.

! delimiter for valid command

? delimiter for invalid command

AA address of response module(00 to FF)

(Data) Name of module

Example :

Command : \$01M Receive : !017042

Read address 01 module name, return name 7042.

Command : \$03M Receive : !037060D

Read address 03 module name, return name 7060D.

Related Command :

Sec.2.16 ~AAO(Data)

2.11 \$AAC

Description : Clear Latched Digital Input

Command : \$AAC[CHK](cr)

\$ delimiter character

AA address of setting module (00 to FF)

C command for clear latched digital input

Response : Valid Command : !AA[CHK](cr)

Invalid Command : ?AA[CHK](cr)

Syntax error or communication error may get no response.

! delimiter for valid command

? delimiter for invalid command

AA address of response module(00 to FF)

Example :

Command : \$01L0 Receive : !01FFFF00

Read address 01 latch-low data, return FFFF.

Command : \$01C Receive : !01

Clear address 01 latched data, return success.

Command : \$01L0 Receive : !01000000

Read address 01 latch-low data, return 0000.

Related Command :

Sec2.13 \$AALS

Note :

The command is useless for I-7042/42D/43/43D/66/66D/67/67D.

2.12 \$AACN

Description : Clear Digital Input Counter

Command : \$AACN[CHK](cr)

\$ delimiter character

AA address of setting module (00 to FF)

C command for clear digital input counter

N digital counter channel N to clear

Response : Valid Command : !AA[CHK](cr)

Invalid Command : ?AA[CHK](cr)

Syntax error or communication error may get no response.

! delimiter for valid command

? delimiter for invalid command

AA address of response module(00 to FF)

Example :

Command : #010 Receive : !0100123

Read address 01 input channel 0 counter value, return 123.

Command : \$01C0 Receive : !01

Clear address 01 input channel 0 counter value, return success.

Command : #010 Receive : !0100000

Read address 01 input channel 0 counter value, return 0.

Related Command :

Sec2.4 #AAN

Note :

The command is useless for I-7042/42D/43/43D/66/66D/67/67D.

2.13 \$AALS

Description : Read Latched Digital Input

Command : \$AALS[CHK](cr)

\$ delimiter character

AA address of reading module (00 to FF)

L command for read latched digital input

S 1 = select latch high status, 0 = select latch low status

Response : Valid Command : !(Data)[CHK](cr)

Invalid Command : ?AA[CHK](cr)

Syntax error or communication error may get no response.

! delimiter for valid command

? delimiter for invalid command

AA address of response module(00 to FF)

(Data) readed status (Ref *Sec.1.9*).1= the input channel is latched,
0=the input channel is not latched.

Example :

Command : \$01L1 Receive : !012300

Read address 01 latch-high data, return 0123.

Command : \$01C Receive : !01

Clear address 01 latched data, return success.

Command : \$01L1 Receive : !000000

Read address 01 latch-high data, return 0.

Related Command :

Sec2.11 \$AAC

Note :

The command is useless for I-7042/42D/43/43D/66/66D/67/67D.

2.14 @AA

Description : Read Digital Input/Output Status

Command : @AA[CHK](cr)

@ delimiter character

AA address of reading module (00 to FF)

Response : Valid Command : >(Data)[CHK](cr)

Invalid Command : ?AA[CHK](cr)

Syntax error or communication error may get no response.

> delimiter for valid command

? delimiter for invalid command

AA address of response module(00 to FF)

(Data) readed DIO status (Ref *Sec.1.9*)

Example :

Command : @01 Receive : >0F00

 Read address 01 DIO status, return 0F00.

Related Command :

Sec.2.8 \$AA6

Related Topics :

Sec.1.9 Configuration Tables

2.15 @AA(Data)

Description : Set Digital Output

Command : @AA(Data)[CHK](cr)

@ delimiter character

AA address of setting module (00 to FF)

(Data) output value, the data format is following :

(Data) is one character for output channel less than 4

For I-7060/60D, from 0 to F

For I-7063/63D/63A/63AD/63B/63BD, from 0 to 7

(Data) is two characters for output channel less than 8

For I-7044/44D/50/50D, from 00 to FF

For I-7065/65D/65A/65AD/65B/65BD, from 00 to 1F

For I-7066/66D/67/67D, from 00 to 7F

(Data) is four characters for output channel less than 16

For I-7042/42D, from 0000 to 1FFF

For I-7043/43D, from 0000 to FFFF

Response : Valid Command : >[CHK](cr)

Invalid Command : ?[CHK](cr)

Ignore Command : ![CHK](cr)

Syntax error or communication error may get no response.

> delimiter for valid command.

? delimiter for invalid command.

! delimiter for ignore command. The module is in Host Watchdog Timeout Mode, and the output is set to safe value.

Example :

Command : @017 Receive : >

Output address 02 value 7, return success.(The example is suitable for I-7060/60D/63/63D/63A/63AD/63B/63BD)

Command : @0200 Receive : >

Output address 01 value 00, return success.(The example is suitable for I-7044/44D/50/50D/65/65D/65A/65AD/65B/65BD/66/66D/67/67D)

Command : @030012 Receive : !

Output address 03 value 0012, return the module is in host watchdog timeout mode, the output command is ignored.(The example is suitable for I-7042/42D/43/43D)

Related Command :

Sec.2.3 #AABBDD, Sec.2.18 ~AA0, Sec.2.19 ~AA1

Related Topics :

Sec.1.9 Configuration Tables, Set.3.2 Module Status, Sec.3.3 Dual Watchdog Operation, Sec.3.5 Digital Output

Note :

The command is useless for I-7041/41D/52/52D/53/53D.

2.16 ~AAO(Data)

Description : Set Module Name

Command : ~AAO(Data)[CHK](cr)

~ delimiter character

AA address of setting module (00 to FF)

O command for set module name

(Data) new name for module, max 6 characters

Response : Valid Command : !AA[CHK](cr)

Invalid Command : ?AA[CHK](cr)

Syntax error or communication error may get no response.

! delimiter for valid command

? delimiter for invalid command

AA address of response module(00 to FF)

Example :

Command : ~01O7050 Receive : !01

Set address 01 module name 7050, return success.

Command : \$01M Receive : !017050

Read address 01 module name, return name 7050.

Related Command :

Sec.2.10 \$AAM

2.18 ~AA0

Description : Read Module Status

Command : ~AA0[CHK](cr)

~ delimiter character

AA address of reading module (00 to FF)

0 command for read module status

Response : Valid Command : !AASS[CHK](cr)

Invalid Command : ?AA[CHK](cr)

Syntax error or communication error may get no response.

! delimiter for valid command

? delimiter for invalid command

AA address of response module(00 to FF)

SS module status, 00=host watchdog timeout status is clear, 04=host watchdog timeout status is set. The status will store into EEPROM and only may reset by the command ~AA1.

Example :

Refer *Sec.2.21 ~AA3EVV* example

Related Command :

*Sec.2.17 ~***, *Sec.2.19 ~AA1*, *Sec.2.20 ~AA2*, *Sec.2.21 ~AA3EVV*, *Sec.2.22 ~AA4V*, *Sec.2.23 ~AA5V*

Related Topic :

Sec.3.2 Module Status, *Sec.3.3 Dual Watchdog Operation*

2.19 ~AA1

Description : Reset Module Status

Command : ~AA1[CHK](cr)

~ delimiter character

AA address of setting module (00 to FF)

1 command for reset module status

Response : Valid Command : !AA[CHK](cr)

Invalid Command : ?AA[CHK](cr)

Syntax error or communication error may get no response.

! delimiter for valid command

? delimiter for invalid command

AA address of response module(00 to FF)

Example :

Refer *Sec.2.21 ~AA3EVV* example

Related Command :

*Sec.2.17 ~***, *Sec.2.18 ~AA0*, *Sec.2.20 ~AA2*, *Sec.2.21 ~AA3EVV*, *Sec.2.22 ~AA4V*, *Sec.2.23 ~AA5V*

Related Topic :

Sec.3.2 Module Status, *Sec.3.3 Dual Watchdog Operation*

2.20 ~AA2

Description : Read Host Watchdog Timeout Value

Command : ~AA2[CHK](cr)

~ delimiter character

AA address of reading module (00 to FF)

2 command for read host watchdog timeout value

Response : Valid Command : !AAVV[CHK](cr)

Invalid Command : ?AA[CHK](cr)

Syntax error or communication error may get no response.

! delimiter for valid command

? delimiter for invalid command

AA address of response module(00 to FF)

VV timeout value in HEX format, each count is 0.1 second,
01=0.1 second and FF=25.5 seconds

Example :

Refer *Sec.2.21 ~AA3EVV* example

Related Command :

*Sec.2.17 ~***, *Sec.2.18 ~AA0*, *Sec.2.19 ~AA1*, *Sec.2.21 ~AA3EVV*, *Sec.2.22 ~AA4V*, *Sec.2.23 ~AA5V*

Related Topic :

Sec.3.2 Module Status, *Sec.3.3 Dual Watchdog Operation*

2.21 ~AA3E VV

Description : Set Host Watchdog Timeout Value

Command : ~AA3E VV[CHK](cr)

~ delimiter character

AA address of setting module (00 to FF)

3 command for set host watchdog timeout value

E 1=Enable/0=Disable host watchdog

VV timeout value, from 01 to FF, each for 0.1 second

Response : Valid Command : !AA[CHK](cr)

Invalid Command : ?AA[CHK](cr)

Syntax error or communication error may get no response.

! delimiter for valid command

? delimiter for invalid command

AA address of response module(00 to FF)

Example :

Command : ~010 Receive : !0100

Read address 01 module status, return host watchdog timeout status is clear.

Command : ~013164 Receive : !01

Set address 01 host watchdog timeout value 10.0 seconds and enable host watchdog, return success.

Command : ~012 Receive : !0164

Read address 01 host watchdog timeout value, return 10.0 seconds.

Command : ~** No response

Reset the host watchdog timer.

Wait for about 10 seconds and don't send command ~**, the LED of module will go to flash. The flash LED indicates the host watchdog timeout status is set.

Command : ~010 Receive : !0104

Read address 01 module status, return host watchdog timeout status is set.

Command : ~011 Receive : !01

Reset address 01 host watchdog timeout status, return success. And the LED of this module stop flash.

Command : ~010 Receive : !0100

Read address 01 module status, return host watchdog timeout status is clear.

Related Command :

*Sec.2.17 ~**, Sec.2.18 ~AA0, Sec.2.19 ~AA1, Sec.2.20 ~AA2, Sec.2.22 ~AA4V, Sec.2.23 ~AA5V*

Related Topic :

Sec.3.2 Module Status, Sec.3.3 Dual Watchdog Operation

2.22 ~AA4V

Description : Read PowerOn/Safe Value.

Command : ~AA4V[CHK](cr)

~ delimiter character

AA address of reading module (00 to FF)

4 command for read PowerOn/Safe value

V P = read PowerOn value, S = read Safe value

Response : Valid Command : !AA(Data)[CHK](cr)

Invalid Command : ?AA[CHK](cr)

Syntax error or communication error may get no response.

! delimiter for valid command

? delimiter for invalid command

AA address of response module(00 to FF)

(Data) PowerOn Value or Safe Value

For I-7042/42D/43/43D (Data) is VVVV, where VVVV is the PowerOn Value (or Safe Value).

For other modules, (Data) is VV00, where VV is the PowerOn Value(or Safe Value).

Example :

Command : @010000 Receive : >

Output address 01 value 0000, return success.

Command : ~015S Receive : !01

Set address 01 Safe Value, return success.

Command : @01FFFF Receive : >

Output address 01 value FFFF, return success.

Command : ~015P Receive : !01

Set address 01 PowerOn Value, return success.

Command : ~014S Receive : !010000

Read address 01 Safe Value, return 0000.

Command : ~014P Receive : !01FFFF

Read address 01 PowerOn Value, return FFFF.

Related Command :

*Sec.2.17 ~**, Sec.2.18 ~AA0, Sec.2.19 ~AA1, Sec.2.20 ~AA2,
Sec.2.21 ~AA3EUV, Sec.2.23 ~AA5V*

Related Topic :

Sec.3.2 Module Status, Sec.3.3 Dual Watchdog Operation

Note :

The command is useless for I-7041/41D/52/52D/53/53D.

2.23 ~AA5V

Description : Set PowerOn/Safe Value.

Command : ~AA5V[CHK](cr)

~ delimiter character

AA address of setting module (00 to FF)

5 command for set PowerOn/Safe Value

V P = set current output as PowerOn Value, S = set current output as Safe Value

Response : Valid Command : !AA[CHK](cr)

Invalid Command : ?AA[CHK](cr)

Syntax error or communication error may get no response.

! delimiter for valid command

? delimiter for invalid command

AA address of response module(00 to FF)

Example :

Command : @01AA Receive : >

Output address 01 value AA, return success.

Command : ~015P Receive : !01

Set address 01 PowerOn Value, return success.

Command : @0155 Receive : >

Output address 01 value 55, return success.

Command : ~015S Receive : !01

Set address 01 Safe Value, return success.

Command : ~014P Receive : !01AA00

Read address 01 PowerOn Value, return PowerOn Value AA.

Command : ~014S

Receive : !015500

Read address 01 Safe Value, return Safe Value 55.

Related Command :

*Sec.2.17 ~**, Sec.2.18 ~AA0, Sec.2.19 ~AA1, Sec.2.20 ~AA2,
Sec.2.21 ~AA3EVV, Sec.2.22 ~AA4V*

Related Topic :

Sec.3.2 Module Status, Sec.3.3 Dual Watchdog Operation

Note :

The command is useless for I-7041/41D/52/52D/53/53D.

3. Application Note

3.1 INIT* pin Operation

Each I-7000 module has a build-in EEPROM to store configuration information such as address, type, baudrate and other information. Sometimes, user may forget the configuration of the module. Therefore, the I-7000 have a special mode named “**INIT mode**”, to help user to resolve the problem. The “**INIT mode**” is setting as **Address=00, baudrate=9600bps, no checksum**

To enable INIT mode, please following these steps:

Step1. Power off the module

Step2. Connect the INIT* pin with the GND pin.

Step3. Power on

Step4. Send command \$002(cr) in 9600bps to read the configuration stored in the module’s EEPROM.

Refer to “**7000 Bus Converter User Manual**” *Sec.5.1* and “**Getting Start**” for more information.

3.2 Module Status

PowerOn Reset or **Module Watchdog Reset** will let all output goto **PowerOn Value**. And the module may accept the host’s command to change the output value.

Host Watchdog Timeout will let all output goto **Safe Value**.The module’s status (readed by command ~AA0) will be 04, and the output command will be ignored.

3.3 Dual Watchdog Operation

Dual Watchdog = Module Watchdog + Host Watchdog

The Module Watchdog is a hardware reset circuit to monitor the module's operating status. While working in harsh or noisy environment, the module may be down by the external signal. The circuit may let the module to work continues and never halt.

The Host Watchdog is a software function to monitor the host's operating status. Its purpose is to prevent the network from communication problem or host halt. When the timeout interval expired, the module will turn all outputs to predefined Safe Value. This can prevent the controlled target from unexpected situation.

The I-7000 module with Dual Watchdog may let the control system more reliable and stable.

3.4 Reset Status

The Reset Status is set while the module power on or reset by Module Watchdog, and is cleared while the command read Reset Status (\$AA5) applied. This is useful for user to check the module's working status. When the Reset Status is set means the module is reset and the output may be changed to the PowerOn Value. When the Reset Status is clear means the module is not reseted, and the output is not changed.

3.5 Digital Output

The module's output have 3 different situation :

<1> **Safe Value.** If the host watchdog timeout status is set, the output is set to Safe Value. While the module receive the

output command, like @AA(Data) or #AABBDD, the module will ignore the command and return ‘!’, and will not change the output to the output command value. **The host watchdog timeout status is set and store into EEPROM while the host watchdog timeout interval expired, and only can be cleared by command ~AA1.** If user want to change the output, he need to clear the host watchdog timeout status firstly, and send output command to change the output into desired value.

<2> **PowerOn Value.** Only the module reseted, and the host watchdog timeout status is clear, the module’s output is set to predefined PowerOn Value.

<3> **Output command value.** If the host watchdog timeout status is clear, and user issue a digital output command, like @AA(Data) or #AABBDD, to module for changing the output value. The module will response success (receive >).

3.6 Latch Digital Input

For example, user connect the key switch to digital input channel of a digital input/output module and want to read the key stoke. The key input is a pulse digial input, and user will lost the strike. While reading by command \$AA6 in A and B position, the response is that no key stroke and he will lose the key stroke information. Respectly, the read latch-low digital input command \$AAL0 will slove this problem. When issue \$AAL0 command in A and B position, the response denote that there is a low pulse between A and B position for a key storke.

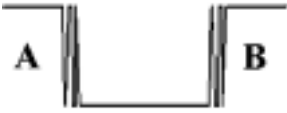

4 DN Module

4.1 DN-SSR4

Output Channel : 4 Solid State Relay Contact

Output Specification :

Type : Zero-Cross AC Solid-State Relay Output

Rated Load Voltage : 200 to 240 VAC

Rated Load Current : 4 Arms

Surge Current : 50A

Max. Off-State Leakage Current : 5.0 mA

Operate Time : 1/2 cycle of voltage sine wave + 1mS

Input Impedance : 1.5K Ohms

Din-Rail mounted

Power Input : +24VDC

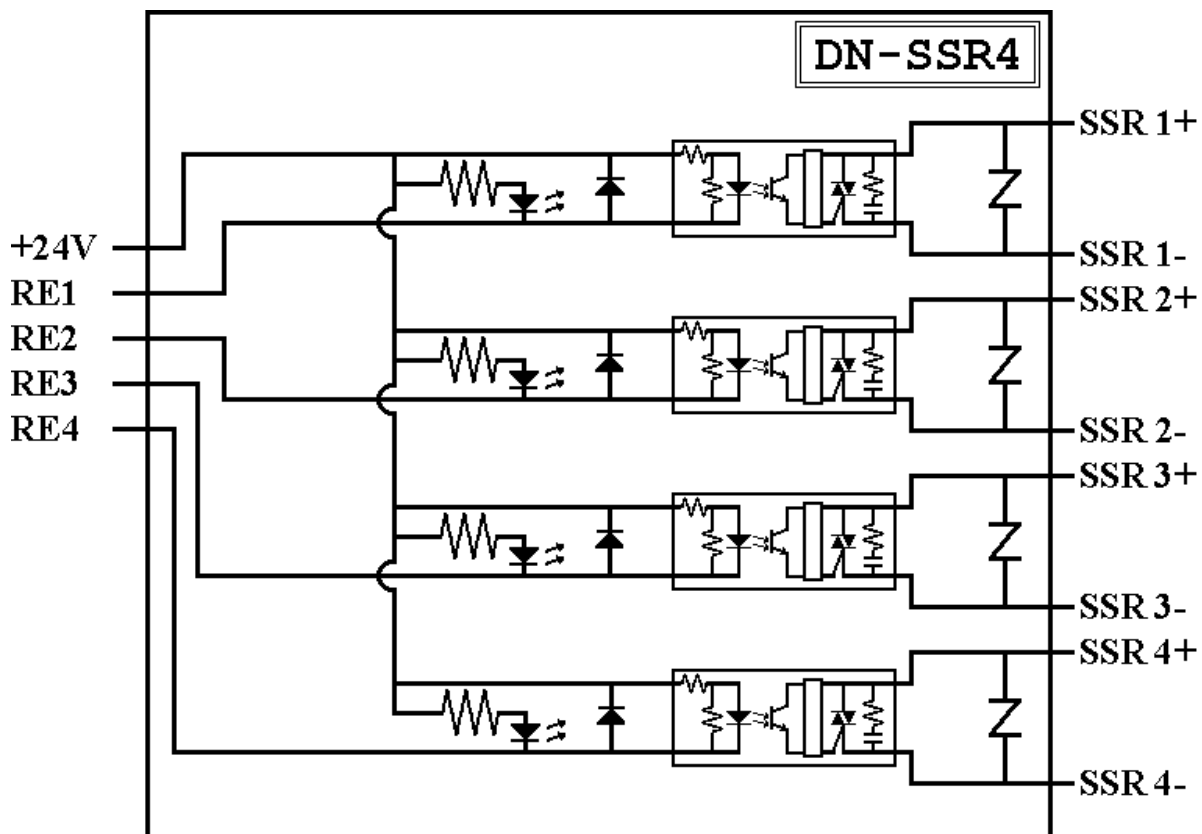

4.2 DN-PR4

Output Channel : 4 Relay Contact

Output Specification :

Type : 1 FormC Relay Contact

Norminal Load : 5A@250VAC, 5A@30VDC

Max. Switching Power : 1250 VAC

Max. Switching Voltage : 250VAC, 150VDC

Max. Switching Current : 5A

Mechanical/Electrical Life : Min. $10 \cdot 10^6 / 100 \cdot 10^3$ ops.

Operate/Release Time : Max. 10mS/5mS

Dielectric Strength : 2000VAC 1 minute

Nominal Coil Power : 360mW

Din-Rail mounted

Power Input : 24VDC

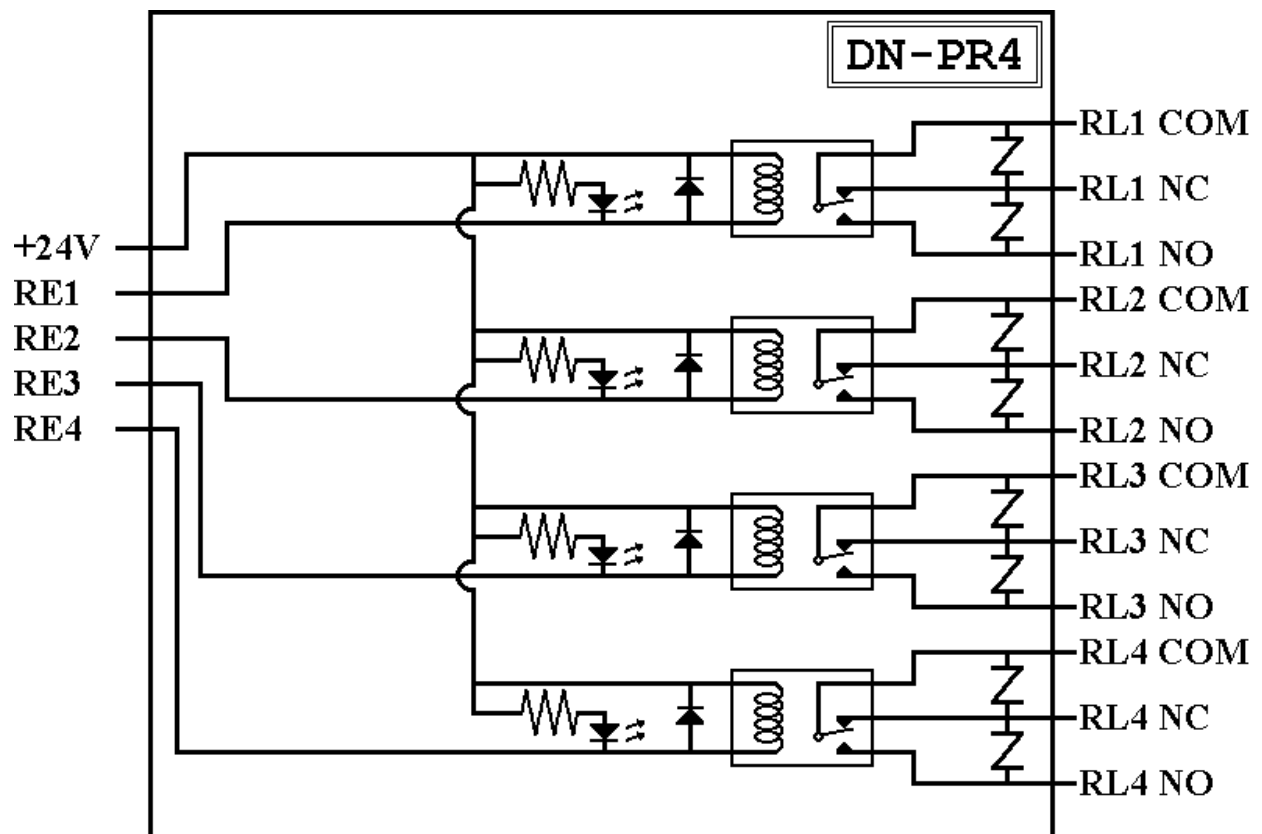

4.3 RM-104, RM-108, RM-116

Output Channel : 4/8/16 Relay Contact

Output Specification :

Type : 1 FormC Relay Contact

Rated Load : 16A@250VAC

Max. Switching Voltage : 400VAC

Max. Peak Current : 30A

Standard Contact Material : AgCd0

Din-Rail mounted

Dimension :

RM-104 : 78mm * 77mm

RM-108 : 135mm * 77mm

RM-116 : 270mm * 77mm

Power Input : 24VDC

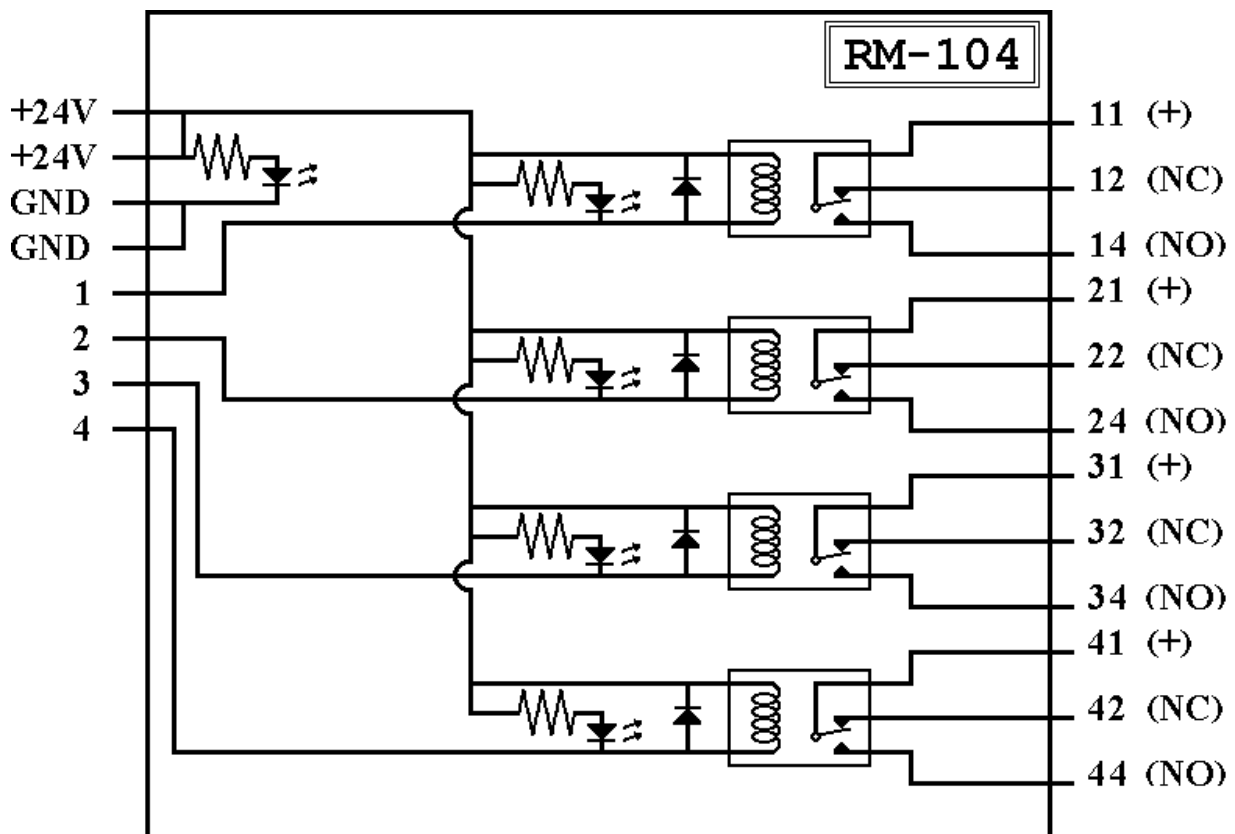

4.4 RM-204, RM-208, RM-216

Output Channel : 4/8/16 Relay Contact

Relay Specification :

- Type : 2 FormC
- Rated Load : 5A@250VAC
- Max. Switching Voltage : 400VAC
- Max. Peak Current : 10A
- Standard Contact Material : Ag Nt

Din-Rail mounted

Dimension :

- RM-204 : 78mm * 77mm
- RM-208 : 135mm * 77mm
- RM-216 : 270mm * 77mm

Power Input : 24VDC

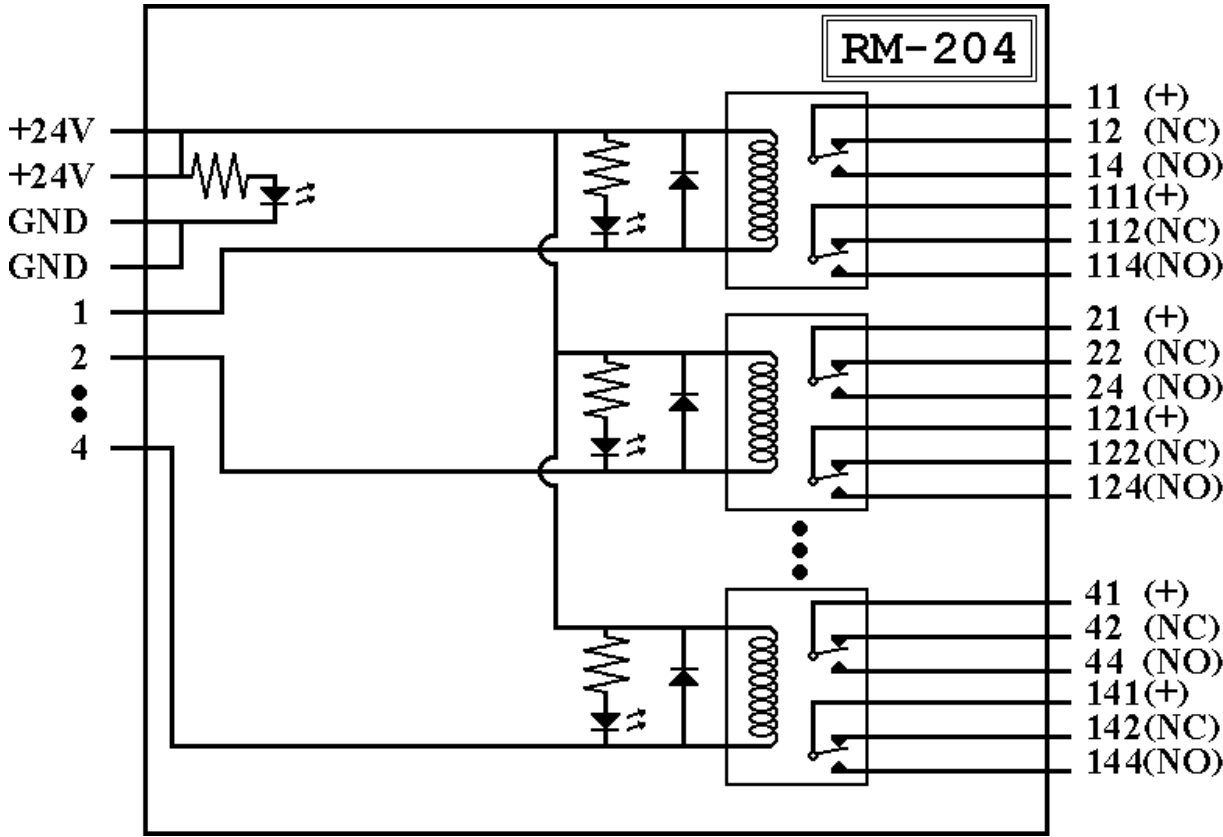

4.5 Application

The DN Modules are the IO extension of I-7000 modules. These modules may drive more power and heavy load in application. User may use I-7000 modules, like I-7043 or others, to control the DN modules to drive loads.

